

ÖZEL ÖĞRENCİLER İÇİN
UYARLANMIŞ ETKİNLİKLER
(UYET)

TÜRKÇE

ERKEN OKURYAZARLIK



2



Ankara, 2021

GENEL YAYIN YÖNETMENİ

Mehmet Nezir GÜL

YAYIN KOORDİNATÖRÜ

Kürşat DULKADİR

EDİTÖRLER

Esra DEMELİ

Nazik Selcen YUMAK

Ozan Can CEYLAN

Funda GÜNDOĞDU

Ayşenur ŞAHİN

YAZARLAR

Aysun GÜLAP KOÇ

Fazilet BURCU

Gül AKGÜL

Kübra YÜCEKAYA

Melisa KOZ İLİKLİER

Neslihan YILMAZ

Oğuz BURCU

SON OKUMA

Elif ALPHAN

Gülşah ELKAAN

Rahime TURHAN

Sabit ERHAN

Yasemin Dilek ALTINTAŞ

Yeşim GÜMÜŞTEKİN

GÖRSEL TASARIM VE RESİMLEME

Sude Ajans Reklam Org. Tan. Ltd. Şti.

ISBN: 978-975-11-5570-2

Her hakkı saklıdır. Bu yayının tümü ya da bir bölümü T. C. Millî Eğitim Bakanlığından izin almaksızın hiçbir biçimde çoğaltılamaz, basılıp yayınlanamaz.



İSTİKLÂL MARŞI

Korkma, sönmez bu şafaklarda yüzen al sancak;
Sönmeden yurdumun üstünde tüten en son ocak.
O benim milletimin yıldızıdır, parlayacak;
O benimdir, o benim milletimindir ancak.

Çatma, kurban olayım, çehreni ey nazlı hilâl!
Kahraman ırkıma bir gül! Ne bu şiddet, bu celâl?
Sana olmaz dökülen kanlarımız sonra helâl.
Hakkıdır Hakk'a tapan milletimin istiklâl.

Mehmet Âkif Ersoy

ANDIMIZ

Türküm, doğruyum, çalışkanım,

İlkem küçüklerimi korumak, büyüklerimi saymak; yurdumu, milletimi

özümnden çok sevmektir.

Ülküm yükselmek, ileri gitmektir.

Ey Büyük Atatürk!

Açtığın yolda, gösterdiğin hedefe durmadan yürüyeceğime ant içerim.

Varlığım Türk varlığına armağan olsun.

Ne mutlu Türküm diyene!

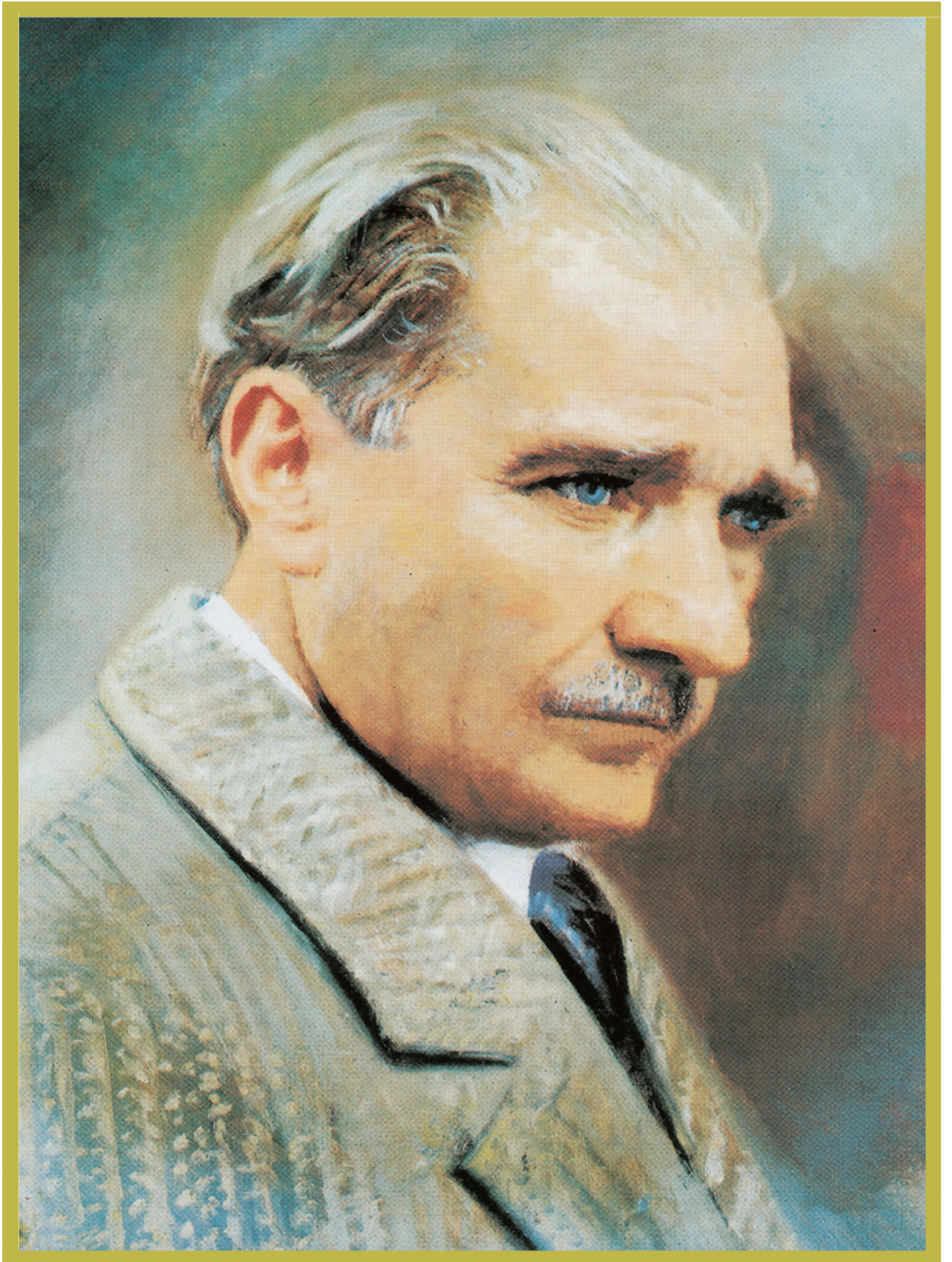

MUSTAFA KEMAL ATATÜRK

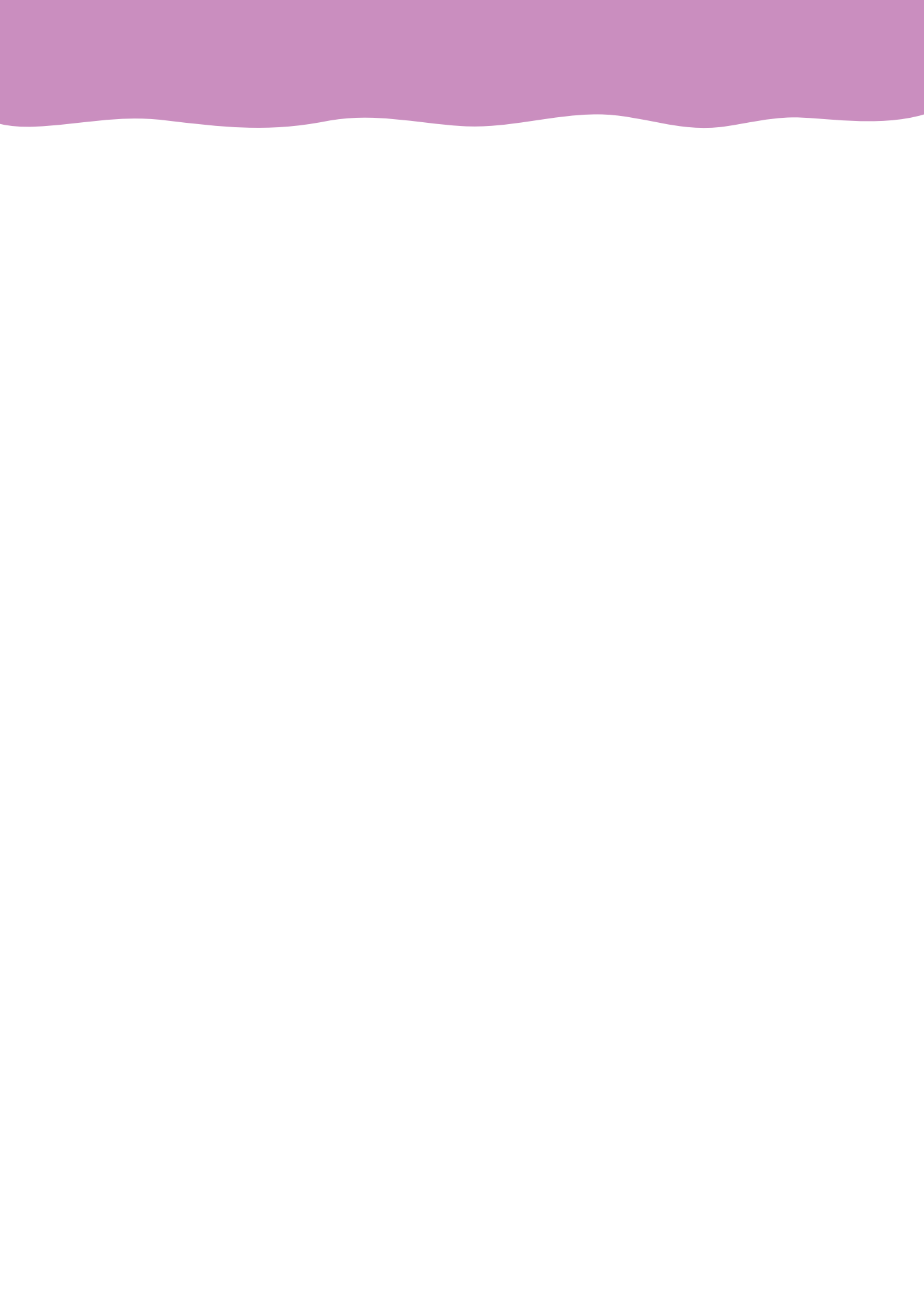

İÇİNDEKİLER

YAZI FARKINDALIĞI

Yazının soldan sağa olan yönünü işaret eder./Yazıdaki satırların akış yönünü işaret eder./Yazının sayfa yönünü işaret eder./Birkaç cümlelik bir yazıda yazının başlangıç ve bitiş sözcüklerini/gösterir.....	12
Çıkış, pastane vb. çevresel yazıları okur.	22
Yazı içinde bir sözcüğü gösterir.	25
Yazılı olarak sunulan farklı sözcükler arasından gösterilen sözcük ile aynı olan bir sözcüğü gösterir.....	27
Yazılı bir cümle içinde birbirinin aynı olan sözcükleri gösterir.....	29
Yazı içinde sözcükler arasındaki boşlukları gösterir.....	31
Yazı içinde büyük bir harf gösterir.....	33
Yazı içinde küçük bir harf gösterir.....	35
Sözcük içinde birbirinin aynı olan harfleri gösterir.....	37
Yazı içinde temel noktalama işaretlerini gösterir.....	38

SES BİLGİSEL FARKINDALIK

Söylenen bir cümlede eksik bırakılan sözcüğü tamamlar.	40
Verilen bir sözcük ile farklı cümleler üretir.	43
Basit cümleleri sözcüklerine ayırır.....	44
Bir cümledeki ilk, son ya da ortadaki sözcüğü söyler.	46
Bir sözcüğün cümledeki yerini söyler.	48
Cümledeki sözcük sayısını söyler.....	50
İsmi hecelenerek söylenen bir nesnenin görselini gösterir.....	52
Basit sözcükleri ve cümleleri hecelerine ayırır.	54
Söylenen basit bir sözcükteki hece sayısını söyler.....	56
Bir sözcükte söylenmeyen/eksik bırakılan son heceyi söyler.....	58
Söylenen bir hece ile başlayan sözcüklerin görsellerini diğer görseller arasından gösterir.	60
Söylenen bir hece ile başlayan sözcükler söyler.....	62
Uyaklı sözcükleri tekrar eder.	63

İÇİNDEKİLER

Uyaklı tekerlemeleri tekrar eder.....	66
Uyaklı sözcükleri söyler.....	67
Söylenen sözcüklerde uyaklı hecelerin sözcüğün başında ya da sonunda olduğunu söyler.....	70
Aynı sesle başlayan sözcüklerin başında bulunan sesi söyler.....	73
Söylenen bir sözcüğün başında bulunan sesi söyler.....	77
Aynı sesle başlayan sözcükler arasından farklı ses ile başlayan sözcüğü söyler.....	81
Aynı sesle biten sözcüklerin sonunda bulunan sesi söyler.....	85
Söylenen bir sözcüğün sonunda bulunan sesi söyler.....	87
Aynı sesle başlayıp aynı sesle biten sözcükler arasından farklı sesle başlayıp farklı sesle biten sözcükleri söyler.....	89
Aynı sesle biten sözcükler arasından farklı sesle biten sözcüğü söyler.....	91
Son sesi eksik olarak söylenen bir sözcükte eksik söylenen sesi söyler.....	93

HARF BİLGİSİ

Farklı büyük harfler arasından aynı olan büyük harfleri gösterir.....	96
Farklı küçük harfler arasından aynı olan küçük harfleri gösterir.....	101
Aynı büyük harfler arasından farklı olan büyük harfi gösterir.....	106
Aynı küçük harfler arasından farklı olan küçük harfi gösterir.....	110
Görünüşleri birbirine benzer olan harfler arasından farklı olanı gösterir.....	114
Verilen küçük harfler arasından aynı olan harfleri gruplar.....	116
Verilen büyük harfler arasından aynı olan harfleri gruplar.....	120
Karışık olarak verilen büyük-küçük harfleri gruplar.....	123
Büyük ve küçük harflerle oluşturulmuş bir örüntünün altına aynı örüntüyü oluşturur.....	126
Büyük ve küçük harflerle oluşturulmuş bir örüntüde eksik bırakılan son ögeyi bulur.....	129
Büyük ve küçük harflerden oluşturulmuş bir örüntüyü aynı şekilde devam ettirir....	132
Büyük ve küçük harflerden oluşturulmuş bir örüntünün ortasında eksik bırakılan ögeyi bulur.....	134
Sesi söylenen birkaç harfi yazı içinde gösterir.....	136
Birkaç harf yazı içinde gösterildiğinde sesletir.....	141

İÇİNDEKİLER

YAZMAYA HAZIRLIK

Adı söylenen yazı araç gerecini gösterir.....	146
Gösterilen yazı araç gerecinin adını söyler.....	151
Kalemi uygun şekilde tutar.....	153
Kâğıdı doğru şekilde tutar.....	155
Silgiyi uygun şekilde kullanır.....	156
Kalemi kalemıraş ile açar.....	158
Yazı araç gereçlerini temiz ve düzenli kullanmanın önemini fark eder.....	161
Yazı araç gereçlerini çalışma sonunda yerine koyar.....	163
Defterini düzenli kullanır.....	164
Dik çizgileri birleştirir.....	166
Yatay çizgileri birleştirir.....	170
Yuvarlak çizgileri birleştirir.....	173
Eğik çizgileri birleştirir.....	175
Dalgalı çizgileri birleştirir.....	177
Kırık çizgileri birleştirir.....	179
Noktaların üzerinden giderek şekil ve nesne resimleri çizer.....	181
Yatay çizgileri çizer.....	182
Dik çizgileri çizer.....	185
Yuvarlak çizgileri çizer.....	188
Sağa eğik çizgileri çizer.....	191
Sola eğik çizgileri çizer.....	194
Kıvrımlı çizgileri çizer.....	197

ÖN SÖZ

Eğitimin her alanında olduğu gibi özel eğitim alanında da uluslararası standartları takip eden ve dünya ile yarışan Bakanlığımız yeni ve nitelikli hizmetler sunabilmek için pek çok çalışma yürütmektedir. Bunlardan biri de özel eğitim ihtiyacı olan bireylerin hak ettikleri yaşam düzeylerine ulaşabilmelerini ve eğitim imkânlarından en üst düzeyde yararlanabilmelerini sağlamak amacıyla yürütülen özel eğitim materyalleri geliştirme çalışmalarıdır. Materyal geliştirme çalışmalarının esas amacı öğrencilerimize daha nitelikli öğrenme imkânı sunmak, onları görsel ve yazılı olarak desteklemek ve ilgilerini derse çekerek öğrenmelerini kalıcı hâle getirmektir.

Bu amaçla kaynaştırma/bütünleştirme yoluyla eğitim gören öğrencilerimizin akademik derslerine yardımcı kaynak teşkil etmesi amacıyla birçok alanda “Uyarlanmış Etkinlikler (UYET)” hazırlanmıştır.

Türkçe dersinin öğretimi, öğrencilerimizde akademik gelişim ve ilerlemenin olmazsa olmaz bir parçasıdır. Türkçe dersine ilişkin kaynak kitaplar incelendiğinde özel eğitim ihtiyacı olan öğrencilerin bu derste yaşadıkları güçlüklerin giderilmesine ilişkin etkinliklerin sınırlı olduğu görülmektedir. Alanda yaşanan bu eksikliklerin giderilmesini sağlayacak yeni bir kaynak geliştirme ihtiyacı hissedilmiştir. Bu ihtiyaç doğrultusunda özel eğitim ihtiyacı olan öğrenciler için Türkçe dersi müfredatında yer alan kazanımlara yönelik etkinlikleri içeren toplam 15 kitaptan oluşan “Türkçe Dersi Uyarlanmış Etkinlikler Seti” hazırlanmıştır.

“Türkçe Dersi Uyarlanmış Etkinlikler Seti” geliştirilirken özel eğitim ihtiyacı olan öğrencilerin Türkçe dersindeki öğrenmeye hazırlık, erken okuryazarlık, ilk okuma-yazma, okuduğunu anlama, yazılı ifade, dinlediğini anlama, sözlü iletişim gibi birçok alanda yaşadıkları güçlükler göz önünde bulundurulmuştur. Bu sette, kaynaştırma/bütünleştirme yoluyla eğitimlerine devam eden hafif düzeyde zihinsel yetersizliği ve otizm spektrum bozukluğu, öğrenme güçlüğü, dikkat eksikliği ve hiperaktivite bozukluğu ile işitme yetersizliği olan öğrencilerimizin Türkçe dersindeki kazanımları daha kolay ve hızlı öğrenebilmesini sağlayan uyarlanmış etkinliklere yer verilmiştir.

Alanında ilk olan bu çalışma ile hedefimiz yeni, özgün, işlevsel materyaller ile özel eğitim hizmetlerinde öğrencilerin akademik başarılarını destekleyerek okullarımızın kapısını mutluluğa açmaktır.

Bu setin hazırlanması, yayınlanması ve dağıtımında fikir, bilgi ve emeklerini bizimle paylaşan ve setin oluşumunda bize destek veren tüm çalışma arkadaşlarıma teşekkürlerimi sunarım.

Mehmet Nezir GÜL

Özel Eğitim ve Rehberlik Hizmetleri
Genel Müdürü



YAZI FARKINDALIĞI



KONU

Yazının yönünü fark eder.

KAZANIM

Yazının soldan sağa olan yönünü işaret eder.

Yazıdaki satırların akış yönünü işaret eder.

Yazının sayfa yönünü işaret eder.

Birkaç cümlelik bir yazıda yazının başlangıç ve bitiş sözcüklerini gösterir.

ETKİNLİK 1

Bu yazıyı okumak istiyorum.

Nereye okuyacağım? Göster.

Okumaya nereden başlayacağım? Göster.

Okumaya ne tarafa doğru devam edeceğim? Göster.

Okumayı nerede bitireceğim? Göster.

Bu yazıdaki ilk kelimeyi göster.

Bu yazıdaki son kelimeyi göster.



Islak Örtü

Okulda beslenme saatiydi. Elif yiyeceklerini ve suyunu masaya çıkardı. Arkadaşı sıraya çarptı ve Elifin suyu masa örtüsüne döküldü. Öğretmen geldi. Islanan örtüyü kalorifere koydu. Örtü kurudu. Elif çok mutlu oldu.

ETKİNLİK 2

Bu yazıyı okumak istiyorum.

Nereyi okuyacağım? Göster.
Okumaya nereden başlayacağım? Göster.
Okumaya ne tarafa doğru devam edeceğim? Göster.
Okumayı nerede bitireceğim? Göster.
Bu yazıdaki ilk kelimeyi göster.
Bu yazıdaki son kelimeyi göster.



Kırılan Bardak

Ayşe su içmek için mutfağa gitti. Su içerken bardak elinden düştü ve kırıldı. Annesi "Üzülme temizleriz." dedi. Annesi ve Ayşe kırılan bardağı temizledi. Ayşe çok sevindi.

ETKİNLİK 3

Bu yazıyı okumak istiyorum.

- Nereyi okuyacağım? Göster.
Okumaya nereden başlayacağım? Göster.
Okumaya ne tarafa doğru devam edeceğim? Göster.
Okumayı nerede bitireceğim? Göster.
Bu yazıdaki ilk kelimeyi göster.
Bu yazıdaki son kelimeyi göster.



Kaybolan Tavuk

Murat ailesiyle birlikte çiftlikte yaşıyordu. Murat her gün tavukları beslerdi. O gün bir tavuk yoktu. Tavuğun kaybolduğunu fark etti. Bütün aile birlikte tavuğu aradılar ve bir ağacın altında buldular.



ETKİNLİK 4

Bu yazıyı okumak istiyorum.

Nereyi okuyacağım? Göster.
Okumaya nereden başlayacağım? Göster.
Okumaya ne tarafa doğru devam edeceğim? Göster.
Okumayı nerede bitireceğim? Göster.
Bu yazıdaki ilk kelimeyi göster.
Bu yazıdaki son kelimeyi göster.



Sincap

Zeynep ve arkadaşları ormanda yürüyüş yapıyorlardı. Bir süre yürüdükten sonra kuyruğu dala takılmış bir sincap gördüler. Sincap çirpini duruyordu. Ama bir türlü daldan kurtulamıyordu. Zeynep bu duruma çok üzüldü. Hemen sincaba yardım etti. Zeynep, sincabı kurtardığı için çok mutluydu.

ETKİNLİK 5

Bu yazıyı okumak istiyorum.

Nereyi okuyacağım? Göster.
Okumaya nereden başlayacağım? Göster.
Okumaya ne tarafa doğru devam edeceğim? Göster.
Okumayı nerede bitireceğim? Göster.
Bu yazıdaki ilk kelimeyi göster.
Bu yazıdaki son kelimeyi göster.



Bahçedeki Üzümler

Yazları dedeme giderim. Dedemin bahçesinde üzümler var. Dedemle üzüm toplarız. Üzümleri sepetlere koyarız. Anneannem üzümlerden pekmez yapar. Tatlı tatlı üzümleri yemeyi çok severim.



ETKİNLİK 6

Bu yazıyı okumak istiyorum.

- Nereyi okuyacağım? Göster.
Okumaya nereden başlayacağım? Göster.
Okumaya ne tarafa doğru devam edeceğim? Göster.
Okumayı nerede bitireceğim? Göster.
Bu yazıdaki ilk kelimeyi göster.
Bu yazıdaki son kelimeyi göster.



Göldeki Ördek

Haftasonu annem ve babamla birlikte göl kenarına gideriz. Göl kenarında yürümeyi ve kahvaltı etmeyi çok severiz. Yürüyüş yaparken gördüğümüz ördeklere yem veririz.

ETKİNLİK 7

Bu yazıyı okumak istiyorum.

Nereyi okuyacağım? Göster.
Okumaya nereden başlayacağım? Göster.
Okumaya ne tarafa doğru devam edeceğim? Göster.
Okumayı nerede bitireceğim? Göster.
Bu yazıdaki ilk kelimeyi göster.
Bu yazıdaki son kelimeyi göster.



Okul Zili

Sabah olunca hazırlanıp okula giderim. Derslerimi dinlerim. Okul zili çaldığında arkadaşlarımla birlikte teneffüste oyunlar oynarım.

ETKİNLİK 8

Bu yazıyı okumak istiyorum.

- Nereye okuyacağım? Göster.
Okumaya nereden başlayacağım? Göster.
Okumaya ne tarafa doğru devam edeceğim? Göster.
Okumayı nerede bitireceğim? Göster.
Bu yazıdaki ilk kelimeyi göster.
Bu yazıdaki son kelimeyi göster.



Kayıp Cüzdan

Ahmet yerde kayıp bir cüzdan buldu. Bu kimin diye düşündü. Hemen sahibini aramaya başladı. O sırada cüzdanını arayan Canan teyzesi ile karşılaştı. Cüzdanın onun olduğunu anlayınca hemen ona verdi.



ETKİNLİK 9

Bu yazıyı okumak istiyorum.

Nereyi okuyacağım? Göster.
Okumaya nereden başlayacağım? Göster.
Okumaya ne tarafa doğru devam edeceğim? Göster.
Okumayı nerede bitireceğim? Göster.
Bu yazıdaki ilk kelimeyi göster.
Bu yazıdaki son kelimeyi göster.



Salıncak

Beril ile parkta karşılaştık. İkimizde salıncakta sallanmayı çok seviyorduk. Ama bir tane salıncak vardı. Biz de sırayla sallanmaya karar verdik.

ETKİNLİK 10

Bu yazıyı okumak istiyorum.

Nereyi okuyacağım? Göster.
Okumaya nereden başlayacağım? Göster.
Okumaya ne tarafa doğru devam edeceğim? Göster.
Okumayı nerede bitireceğim? Göster.
Bu yazıdaki ilk kelimeyi göster.
Bu yazıdaki son kelimeyi göster.

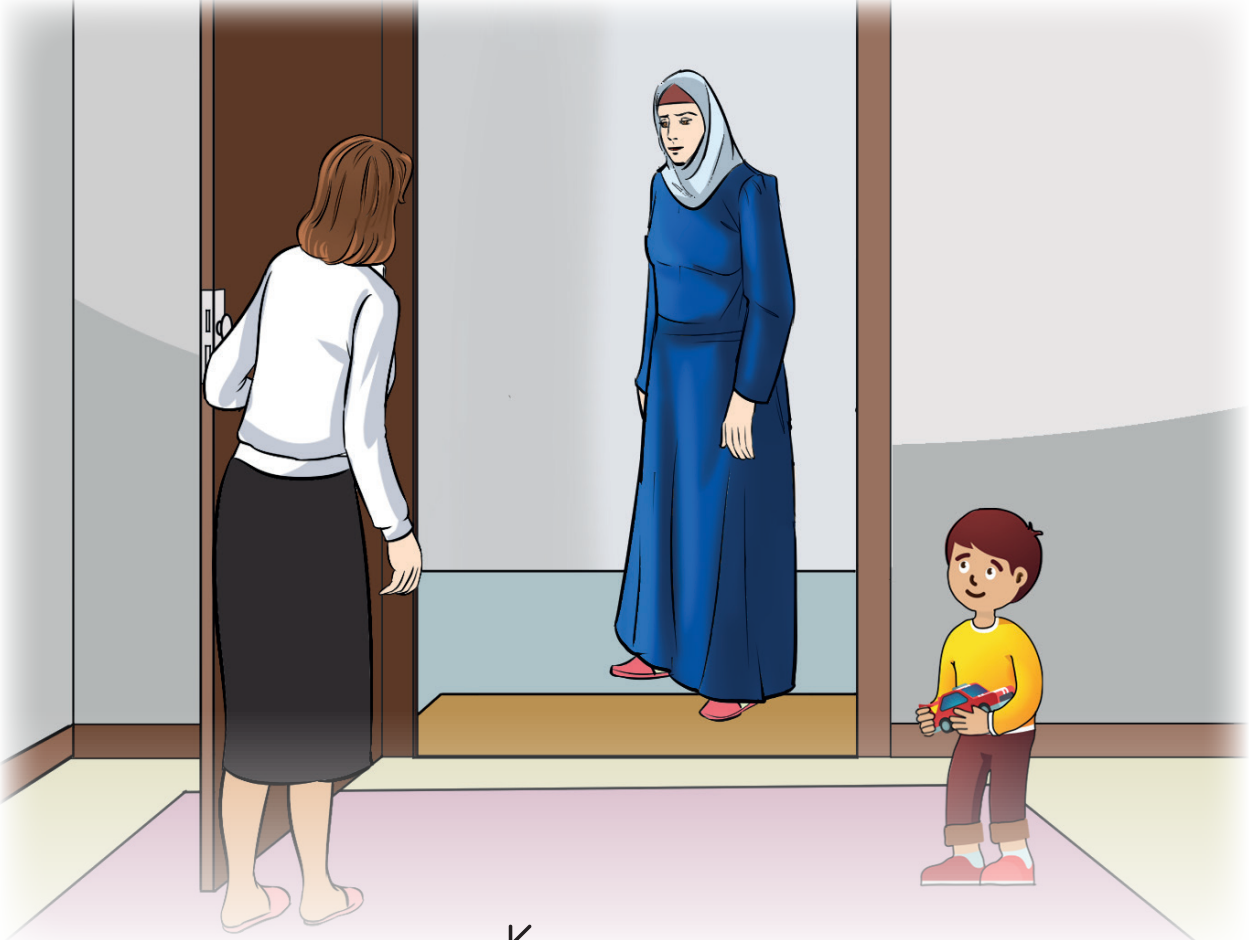

Komşumuz

Annem ile evde oyun oynarken kapı çaldı. Gelen komşumuz Hilal teyzeydi. Hilal teyze anahtarını evde unutmuştu. Hilal teyzeyi kızı gelene kadar eve davet ettik.

KONU

Yaşantısında sık karşılaştığı yazıları okur.

KAZANIM

Çıkış, pastane vb. çevresel yazıları okur.

ETKİNLİK 1

Hasan otoparktan çıkmak istiyor. Hangi yazıyı takip etmelidir? İşaretle.



Yasemin markete gitti. Alışveriş yaparken neye dikkat etmelidir? İşaretle.



ETKİNLİK 2

Nalan ilaç alacak. Hangisine gitmelidir? İşaretle.



Hakkı, dedesine mektup gönderecek. Hangisine gitmelidir? İşaretle.



ETKİNLİK 3

Pelin film izlemek için hangisine gitmelidir? İşaretle.



Ayşe düştü ve yaralandı. Hangisine gitmelidir? İşaretle.

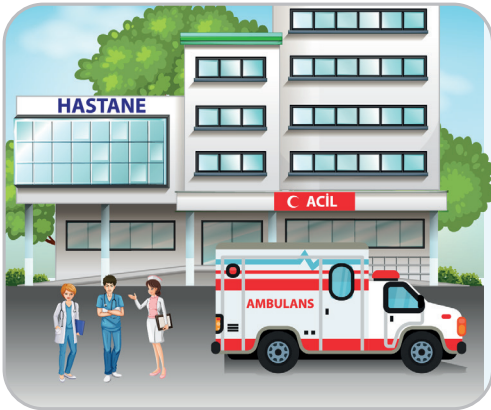

KONU

Yazıya ait kavramları tanır.

KAZANIM

Yazı içinde bir sözcüğü gösterir.

ETKİNLİK 1

Aşağıdaki cümlelere bak. Gösterilen cümleden bir sözcük göster.



- Yeni bir elbise aldım.
- Kardeşimle sinemaya gittik.
- Ayşe balon ile oynamayı çok sever.
- Asya uçak ile teyzesinin yanına gitti.

ETKİNLİK 2

Resimlerin altındaki sözcüğe bak. Cümlelerin içinde aynı sözcüğü bularak işaretle.

 kiraz	Pazardan çilek ve kiraz aldık. Ağaçtan kiraz topladık.
 balık	Babamla balık tutmaya gideceğiz. Her hafta sonu balık yeriz.
 eldiven	Kış mevsiminde eldiven giyerim. Kartopu oynamak için eldiven giymeliyim.
 sepet	Kümeden bir sepet dolusu yumurta topladım. Güzel bir piknik sepeti aldık.
 çiçek	En sevdiğim çiçek papatyadır. Anneler günü için çiçek aldım.

KONU

Yazıya ait kavramları tanır.

KAZANIM

Yazılı olarak sunulan farklı sözcükler arasından gösterilen sözcük ile aynı olan bir sözcüğü gösterir.

ETKİNLİK 1

Sözcüğü incele. Aşağıdaki sözcüklerden aynı olan sözcüğü göster.

araba

araba

saat

kuş

Sözcüğü incele. Aşağıdaki sözcüklerden aynı olan sözcüğü göster.

su

masa

telefon

su

Sözcüğü incele. Aşağıdaki sözcüklerden aynı olan sözcüğü göster.

tabak

okul

tabak

muz

ETKİNLİK 2

Aynı olan sözcükleri eşle.



KONU

Yazıya ait kavramları tanır.

KAZANIM

Yazılı bir cümle içinde birbirinin aynı olan sözcükleri gösterir.

ETKİNLİK 1

Cümlelerdeki renkli olan sözcüklerle içinde aynı sözcük yazan balonu bul. Balonları sözcüklerle aynı renge boya.

Oya **balon** oynamayı çok sever. Balonu şişirmek için eline aldı. **Oya** balonu şişirdi, şişirdi. Balon **patladı**.



ETKİNLİK 2

Cümlelerdeki işaretli olan sözcüklerle içinde aynı sözcük yazan balonu eşle.

Beril kuşları çok seviyordu. Bu yüzden annesi ona mavi bir muhabbet kuşu aldı. Beril kuşu görünce çok mutlu oldu.



KONU

Yazıya ait kavramları tanır.

KAZANIM

Yazı içinde sözcükler arasındaki boşlukları gösterir.

ETKİNLİK 1

Aşağıdaki cümlelere bak. Sözcükler arasındaki boşlukları göster.

- Annem pazara gitti.
- Yüzmeyi çok severim.
- Okulda arkadaşlarımla resim yaptık.
- Asya ile Beril çok iyi arkadaştır.
- Alya bale yapmayı çok sever.
- Hafta sonu pikniğe gideceğiz.



ETKİNLİK 2

Aşağıdaki cümlelere bak. Sözcükler arasındaki boşlukları göster.

- Yeni elbisemi giyip sinemaya gittim.
- Akif ve Burak balık tutmaya gideceklermiş.
- Havalarda çok soğumaya başladı.
- Bilgisayarım bozulunca tamirciye götürdük.
- Müzik dinlemeyi çok severim.
- Kedimin adı Ponçik.



KONU

Yazıya ait kavramları tanır.

KAZANIM

Yazı içinde büyük bir harf gösterir.

ETKİNLİK 1

Aşağıdaki metni incele. Metindeki büyük harfleri daire içine al.



Arı Miya

Küçük arı Miya sadece çiçeklere konar, bal yaparmış. Sonra da uçar gidermiş. Bir gün yine uçarken arkadaşı Moni ile karşılaşmış. Neden birlikte uçmuyoruz ki diye sormuş. Sonra birlikte uçup çiçeklere konmuşlar. Birlikte bal yapıp bol bol eğlenmişler.

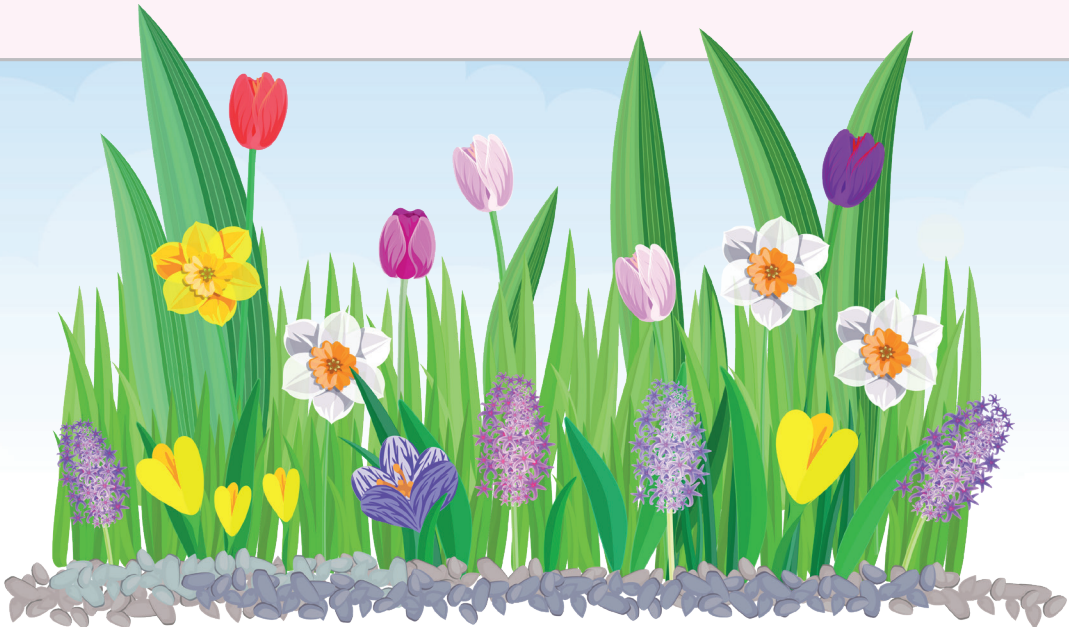

ETKİNLİK 2

Aşağıdaki metni incele. Metindeki büyük harfleri daire içine al.

Mehmet'in Papağanı

Mehmet yeni bir papağan almış. Onu çok seviyormuş. Bir gün papağanını kaybetmiş. Annesi; "Üzülme, şimdi onu arar buluruz." demiş. Biraz sonra papağanın banyoda saklandığını görmüşler. Mehmet ve annesi papağanı bulunca çok mutlu olmuşlar.



KONU

Yazıya ait kavramları tanır.

KAZANIM

Yazı içinde küçük bir harf gösterir.

ETKİNLİK 1

Aşağıdaki metni incele. Metindeki küçük harflerin altını çiz.

Mustafa Yere Düştü

Mustafa bahçede oynarken yere düştü. Mustafa'yı yerde gören Ömer, ona yardım etti. Ömer, Mustafa'yı yerden kaldırdı. Mustafa Ömer'e teşekkür etti.



ETKİNLİK 2

Aşağıdaki metni incele. Metindeki küçük harflerin altını çiz.

Okuyorum

Ben okumayı, yazmayı yeni öğrendim. Bugün kardeşim Hasan'a kitap okudum. Annem çok mutlu oldu. Okuyup yazabilmek çok güzel.



KONU

Yazıya ait kavramları tanır.

KAZANIM

Sözcük içinde birbirinin aynı olan harfleri gösterir.

ETKİNLİK 1

Aşağıdaki sözcüklere bak. Sözcük içinde aynı olan harfleri daire içine al.



MASA



KANEPE



LALE

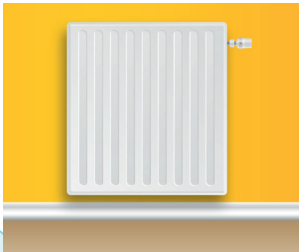

KALORİFER



KEKİK

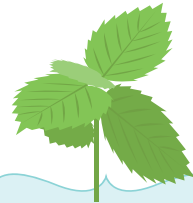

NANE

KONU

Yazıya ait kavramları tanır.

KAZANIM

Yazı içinde temel noktalama işaretlerini gösterir.

ETKİNLİK 1

Aşağıdaki metni incele. Metindeki noktalama işaretlerini daire içine al.

Sevimli Köpek

Ayşe artık ikinci sınıfa gidiyordu, ödevleri çöktü. Derslerini çalıştıktan sonra sevimli köpeğiyle oynayacaktı. Sevimli köpek, Ayşe'yi beklerken biraz süt içti. Ayşe, derslerine çalıştıktan sonra köpeğinin yanına gitti. Şimdi onunla oynayabilirdi. Benimle oynamaya hazır mısın? Hadi şimdi oyun vakti dedi. Birlikte çok eğlendiler.





SES BİLGİSEL FARKINDALIK



KONU

Konuşmadaki sözcükleri ayırır eder.

KAZANIM

Söylenen bir cümlede eksik bırakılan sözcüğü tamamlar.

ETKİNLİK 1

Cümleleri dinle. Cümlelerdeki eksik sözcükleri tamamla.



Ceren okula

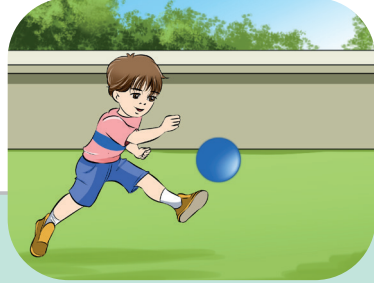

Kerem top



Mine ip

ETKİNLİK 2

Cümleleri dinle. Cümlelerdeki eksik sözcükleri tamamla.



..... süt içiyor.



..... çok sıcak.



.....
defter, çanta tutuyor.

ETKİNLİK 3

Cümleleri dinle. Cümlelerdeki eksik sözcükleri tamamla.



Aslı çalışıyor.



Dayım izliyor.



Nil yiyor.

KONU

Konuşmadaki sözcükleri ayırır eder.

KAZANIM

Verilen bir sözcük ile farklı cümleler üretir.

ETKİNLİK 1

Soruları dinle. Ayakkabı sözcüğü ile ilgili cümlelerini söyle.



Kimin ayakkabısı var?

.....
.....
.....

Ahmet ne giydi?

.....
.....
.....

Baban ayakkabıyı ne yaptı?

.....
.....
.....

Soruları dinle. Araba sözcüğü ile ilgili cümlelerini söyle.



Kim arabaya bindi?

.....
.....
.....

Ne renk araba gördün?

.....
.....
.....

Abin ne sürdü?

.....
.....
.....

KONU

Konuřmadaki sözcükleri ayırır eder.

KAZANIM

Basit cümleleri sözcüklerine ayırır.

ETKİNLİK 1

Dinlediđin cümledeki sözcükleri söyle.

Yemek yedim.

Su içtim.

Okula gittim.

Dinlediđin cümledeki sözcükleri söyle.

- Parkta top oynadım.
- Portakal suyu içtim.
- Yeni defterim çok güzel.
- Dedemi görmeye gittim.

ETKİNLİK 2

Dinlediğin cümledeki sözcükleri söyle.



- Salıncakta sallanmayı çok severim.
- Müzik dersinde arkadaşlarımla şarkı söyledim.
- Sabah uyandığımda annem kahvaltıyı hazırlıyordu.
- Kardeşimle birlikte bakkala gidip süt alacağız.
- Bugün okuldan çıktıktan sonra Burak' la kütüphanede ders çalışacağız.
- Ben, kardeşim ve kuzenim anneannemi ziyarete gitmek için hazırlandık.

KONU

Konuřmadaki sözcükleri ayırır eder.

KAZANIM

Bir cümledeki ilk, son ya da ortadaki sözcüğü söyler.

ETKİNLİK 1

Dinlediđin cümlelerin ilk sözcüğünü söyle.

Mavi bardak kırıldı.

Mustafa mısır yedi.

Akşam yağmur yağdı.



Dinlediđin cümlelerin son sözcüğünü söyle.

Bahçeden elma topladım.

Arkadaşımla bisiklete bindik.

Bugün güzel bir kitap okudum.

Dinlediđin cümlelerin ortasındaki sözcüğünü söyle.



Bugün hava yağmurlu.

Ahmet' le ders çalıştık.

Anneme papatya topladım.

ETKİNLİK 2

Dinlediğin cümlenin ilk sözcüğünü söyle.



Kalemlik aldım.

Çiçekleri çok severim.

Telefonla konuştum.

Dinlediğin cümlenin son sözcüğünü söyle.

Akşam balık yiyeceğiz.

Gizem' le yürüyüş yaptık.

En sevdiğim meyve elmadır.

Dinlediğin cümlenin ortasındaki sözcüğünü söyle.

Nergis mont almış.

Ütü yapmayı severim.

Turuncu rengi severim.



KONU

Konuşmadaki sözcükleri ayırır eder.

KAZANIM

Bir sözcüğün cümledeki yerini söyler.

ETKİNLİK 1

Cümleleri dinle. Kedi sözcüğü cümlenin başında mı ortasında mı sonunda mı? Söyle.



Kedi süt içiyor.

Parkta gördüğüm
hayvan kediydi.

Annem kedi sevdi.

Cümleleri dinle. Telefon sözcüğü cümlenin başında mı ortasında mı sonunda mı? Söyle.



Dedeme telefon ettim.

Arkadaşımla telefonlaştık.

Telefon numaramı
ezberledim.

ETKİNLİK 2

Cümleleri dinle. Balık sözcüğü cümlenin başında mı ortasında mı sonunda mı? Söyle.



Balığımın adı Yıldız.

Gördüğüm en renkli balıklardı.

Babamla balık tuttuk.

Cümleleri dinle. Kalem sözcüğü cümlenin başında mı ortasında mı sonunda mı? Söyle.



Yeni bir kalem aldım.

Aldığım en güzel hediye bu mor kalem.

Kalem en çok kullandığım eşyadır.

KONU

Konuşmadaki sözcükleri ayırır eder.

KAZANIM

Cümledeki sözcük sayısını söyler.

ETKİNLİK 1

Cümleleri dinle. Kaç sözcükten oluşuyor? Söyle.



Köpek havladı.

Ben uçak gördüm.

Annem kek yaptı.

Bugün okulda hikâye
dinledik.

Kahvaltıda peynir,
zeytin, yumurta
yedim.

Hafta sonu arkadaşım
telefonla konuştuk.

ETKİNLİK 2

Cümleleri dinle. Kaç sözcükten oluşuyor? Söyle.



Yeni bir bardak aldım.

Su içmeyi
unutmamalısın.

Minik köpeğimin adı
Kıvrık.

Kitap ayracımı kitabın
arasına koydum.

Kardeşimle yeni yerlere
gitmeyi çok severiz.

Uyanınca balkona çıkıp
temiz hava aldım.

KONU

Sözcüklerdeki heceleri ayırt eder.

KAZANIM

İsmi hecelenerek söylenen bir nesnenin görselini gösterir.

ETKİNLİK 1

Söylediğim sözcüğe ait olan resmi göster.

KO-VA



U-ÇAK



AT-KI



ETKİNLİK 2

Söylediğim sözcüğe ait olan resmi göster.

DO-MA-TES



KA-LEM-LİK

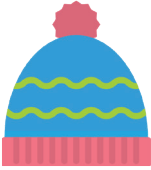

EL-Dİ-VEN



KONU

Sözcüklerdeki heceleri ayırt eder.

KAZANIM

Basit sözcükleri ve cümleleri hecelerine ayırır.

ETKİNLİK 1

Resimde ne var? Heceleyerek söyle.



Resimde ne var? Heceleyerek söyle.



ETKİNLİK 2

Resimde ne oluyor? Heceleyerek söyle.

Okan balık tutuyor.



Arya kalemını açıyor.



Suna montunu giyiyor.



Oya okula servisle gidiyor.



KONU

Sözcüklerdeki heceleri ayırt eder.

KAZANIM

Söylenen basit bir sözcükteki hece sayısını söyler.

ETKİNLİK 1

Dinle. Söylediğim sözcükte kaç hece var? Söyle/işaretle.

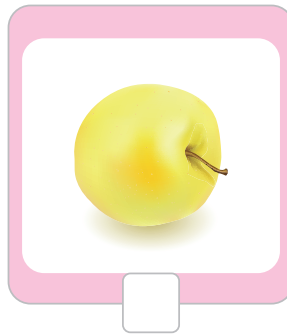
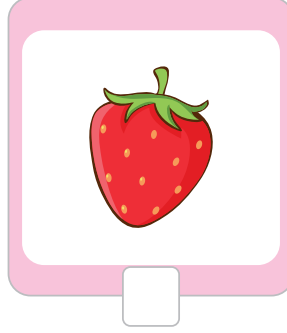

ETKİNLİK 2

Dinle. Söylediğim sözcükte kaç hece var? Söyle/işaretle.

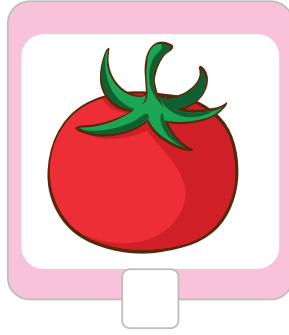

KONU

Sözcüklerdeki heceleri ayırt eder.

KAZANIM

Bir sözcükte söylenmeyen/eksik bırakılan son heceyi söyler.

ETKİNLİK 1

Söylediğim sözcüğün son hecesini söyle.



Ma(kas)



Göz(lük)

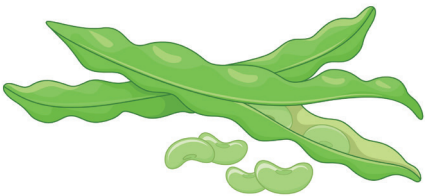

Fasul(ye)



Ara(ba)

ETKİNLİK 2

Söylediğim sözcüğün son hecesini söyle.

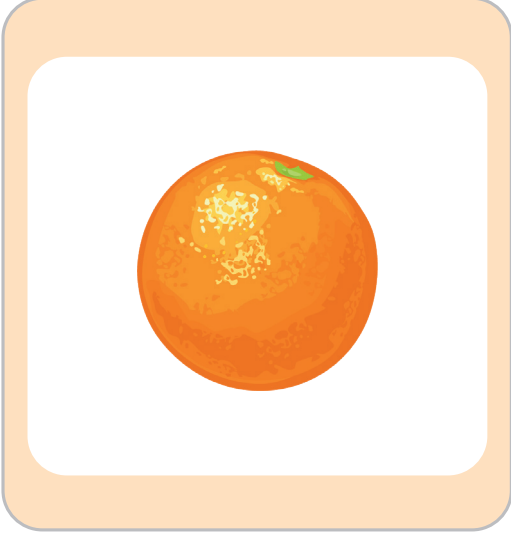

Porta(kal)

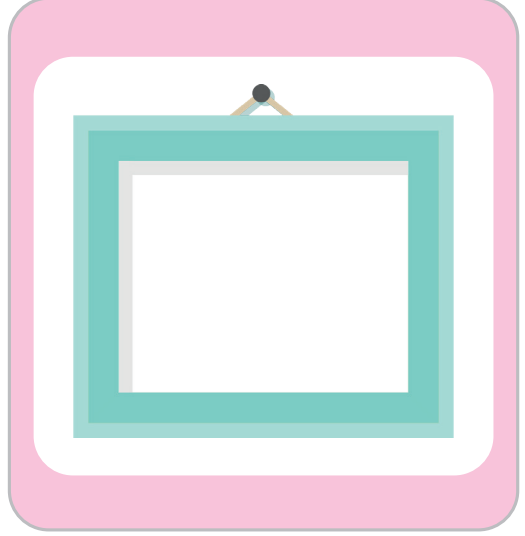

Çerçe(ve)



Yas(tık)



Kitap(lık)

KONU

Sözcüklerdeki heceleri ayırt eder.

KAZANIM

Söylenen bir hece ile başlayan sözcüklerin görsellerini diğer görseller arasından gösterir.

ETKİNLİK 1

"ki" hecesi ile başlayan sözcüklere ait resimleri göster.

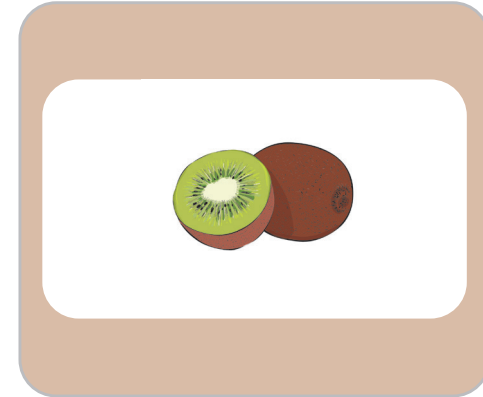
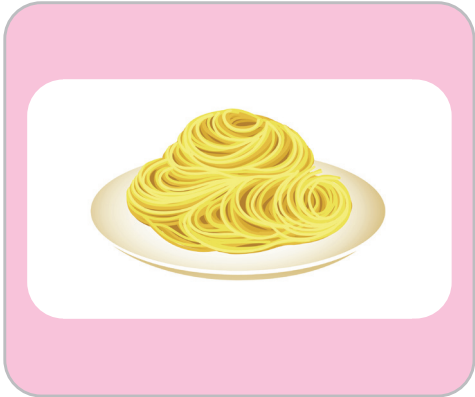
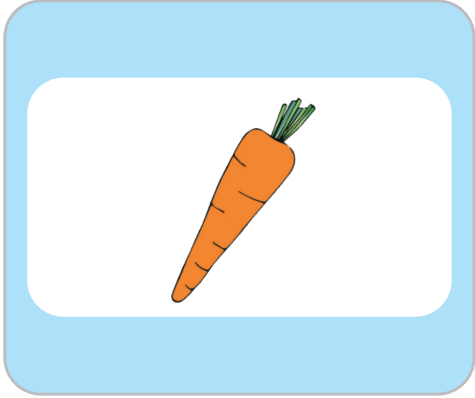
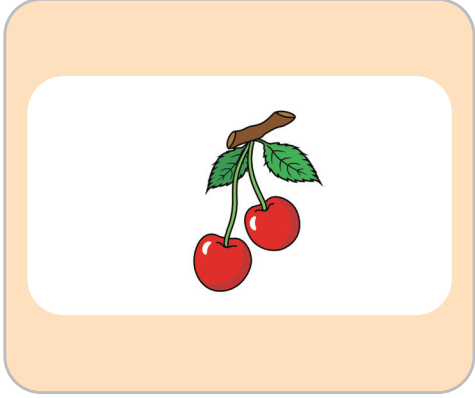

ETKİNLİK 2

"te" hecesi ile başlayan sözcüklere ait resimleri göster.

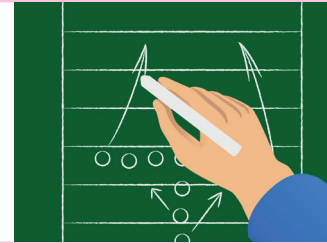

KONU

Sözcüklerdeki heceleri ayırt eder.

KAZANIM

Söylenen bir hece ile başlayan sözcükler söyler.

ETKİNLİK 1

Dinle. Duyduğun heceyle başlayan bir sözcük söyle.

ke

ta

sa

lam

man

bar

el

a

por

ke

ma

sü

KONU

Uyaklı sözcükleri ayırt eder.

KAZANIM

Uyaklı sözcükleri tekrar eder.

ETKİNLİK 1

Dinle, duyduklarını tekrar et.



Nar

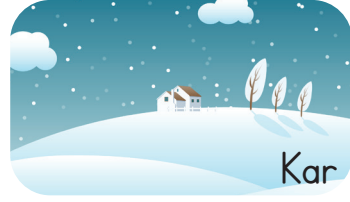

Kar



Baş



Kaş



Kum



Mum



Dil

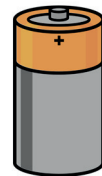

Pil

ETKİNLİK 2

Dinle, duyduklarını tekrar et.



Askı



Atkı



Hamur



Çamur

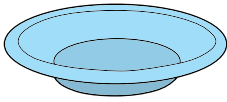

Tabak



Kabak



Sandalye

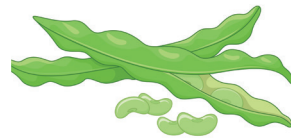

Fasulye

ETKİNLİK 3

Dinle, duyduklarını tekrar et.



Kaş



Baş

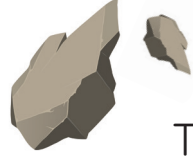

Taş

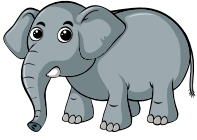

Fil



Dil

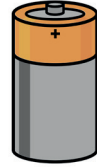

Pil



Muz



Tuz



Buz

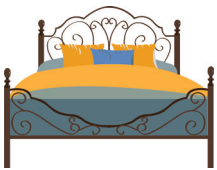

Yatak



Bacak



Çanak

KONU

Uyaklı sözcükleri ayırt eder.

KAZANIM

Uyaklı tekerlemeleri tekrar eder.

ETKİNLİK 1

Dinle, duyduklarını tekrar et.



Leylek lekirdek.
Hani bana çekirdek.
Çekirdeğin içi yok.
Sarı kızın saçı yok.



Saksağan sek sek.
Kuyruğu tümsek.
Kuyruğuna binelim.
Bizim köye gidelim.



Güm güm gümüş.
Al sana yemiş.
Al sana para.
Ver bana yemiş.



Karga karga gak dedi.
Çık şu dala bak dedi.
Çıktım baktım o dala.
Şu karga ne harika.

KONU

Uyaklı sözcükleri ayırt eder.

KAZANIM

Uyaklı sözcükleri söyler.

ETKİNLİK 1

Dinle. İlk duyduğun sözcükle söylenişi benzer olan sözcüğü söyle.



Arı



Muz

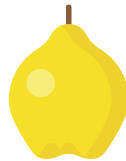

ETKİNLİK 2

Dinle. İlk duyduğun sözcükle söylenişi benzer olan sözcüğü söyle.



Kuş



Domates



ETKİNLİK 3

Dinle. İlk duyduğun sözcükle söylenişi benzer olan sözcüğü söyle.



Fil



Çilek



KONU

Sözcüklerdeki heceleri ayırt eder.

KAZANIM

Söylenen sözcüklerde uyaklı hecelerin sözcüğün başında ya da sonunda olduğunu söyler.

ETKİNLİK 1

Dinle. Duyduğun sözcüklerin başı mı benziyor sonu mu benziyor? Söyle.

İĞNE

İĞDE

TURTA

YUMURTA

KEÇİ

KEDİ

ETKİNLİK 2

Dinle. Duyduğun sözcüklerin başı mı benziyor sonu mu benziyor? Söyle.

ELMA

SARMA

DOLMA

KAŞIK

KABUK

KALEM

TUZ

MUZ

BUZ

ETKİNLİK 3

Dinle. Duyduğun sözcüklerin başı mı benziyor sonu mu benziyor? Söyle.

ÇİÇEK

ETEK

PETEK

MASA

KASA

YASA

KİTAP

SİNCAP

DOLAP

KONU

Sözcüklerin ilk sesini ayırt eder.

KAZANIM

Aynı sesle başlayan sözcüklerin başında bulunan sesi söyler.

ETKİNLİK 1

Dinle. Söylediğim sözcükler hangi sesle başlıyor? Söyle.

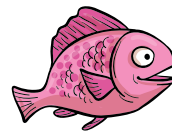
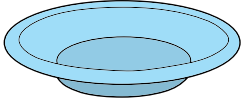
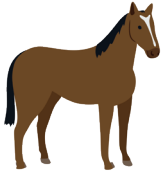

ETKİNLİK 2

Dinle. Söylediğim sözcükler hangi sesle başlıyor? Söyle.

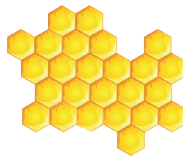
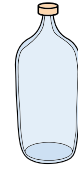
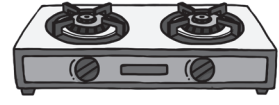

ETKİNLİK 3

Dinle. Söylediğim sözcükler hangi sesle başlıyor? Söyle.

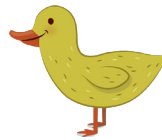
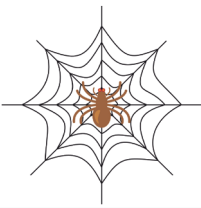
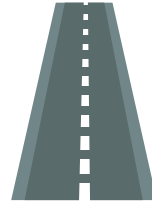
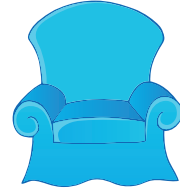

ETKİNLİK 4

Dinle. Söylediğim sözcükler hangi sesle başlıyor? Söyle.

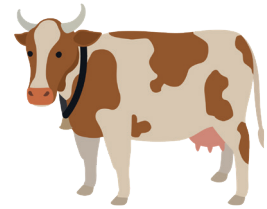
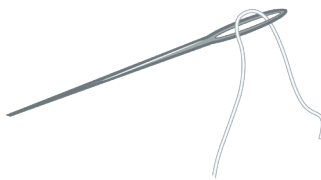
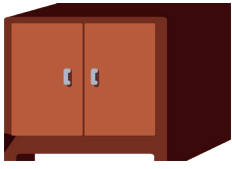

KONU

Sözcüklerin ilk sesini ayırt eder.

KAZANIM

Söylenen bir sözcüğün başında bulunan sesi söyler.

ETKİNLİK 1

Dinle. Söylediğim sözcük hangi sesle başlıyor? Söyle.

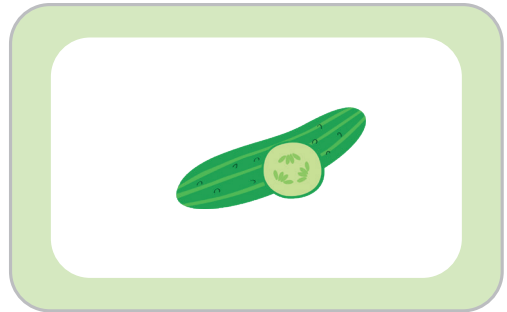
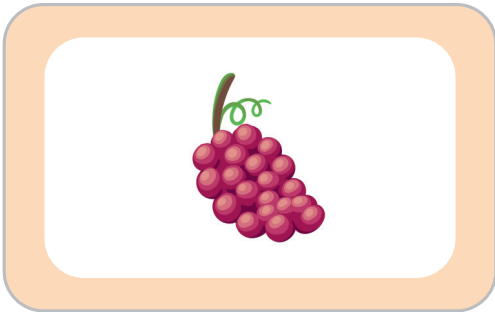
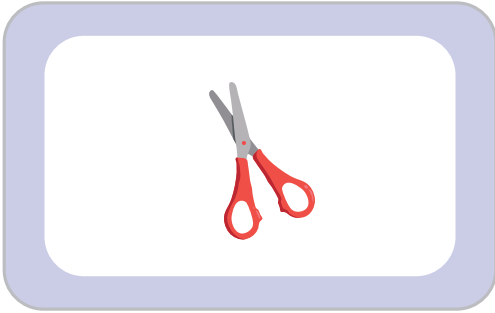
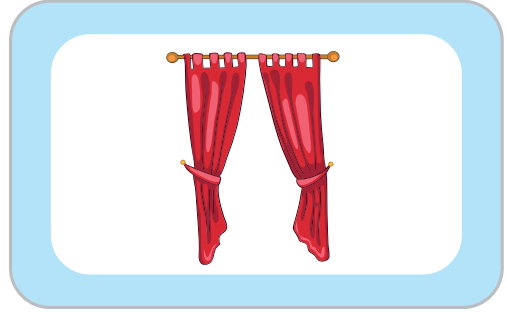
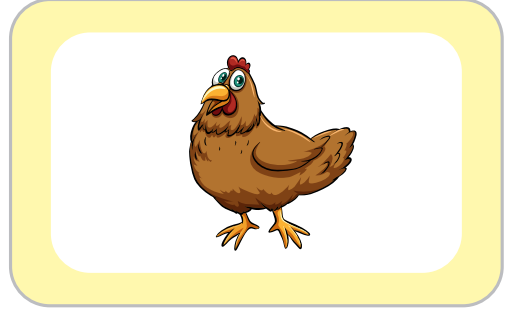

ETKİNLİK 2

Dinle. Söylediğim sözcük hangi sesle başlıyor? Söyle.

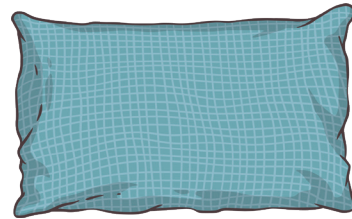
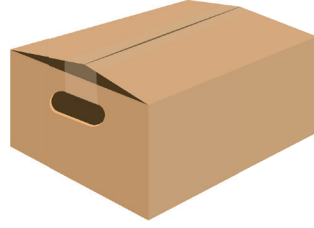
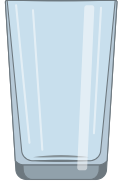

ETKİNLİK 3

Dinle. Söylediğim sözcük hangi sesle başlıyor? Söyle.

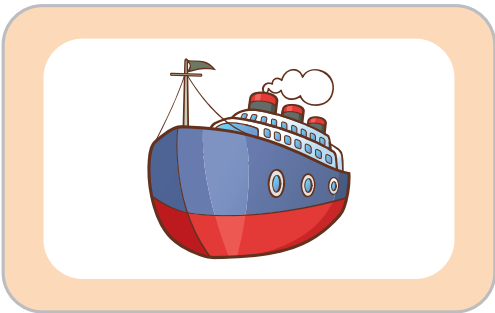
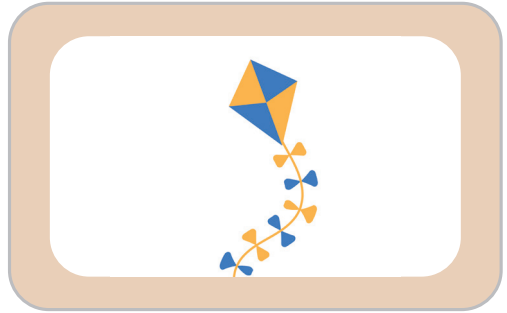
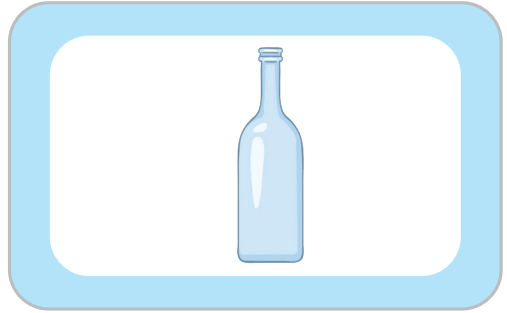
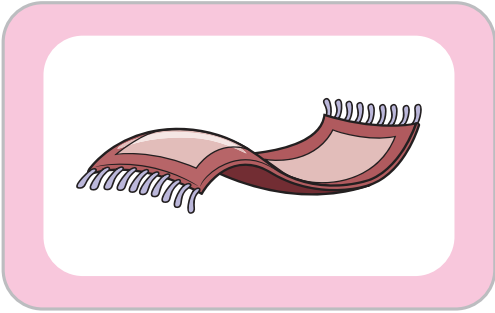
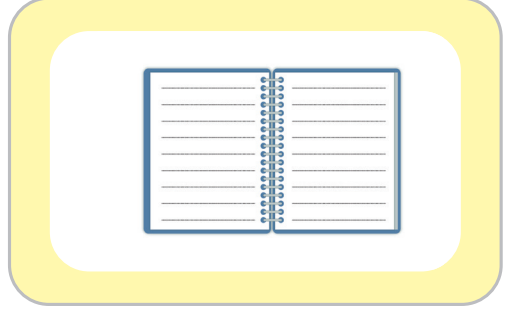

ETKİNLİK 4

Dinle. Söylediğim sözcük hangi sesle başlıyor? Söyle.

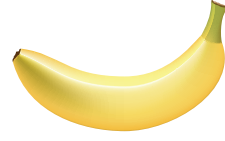

KONU

Uyaklı sözcükleri ayırt eder.

KAZANIM

Aynı sesle başlayan sözcükler arasından farklı ses ile başlayan sözcüğü söyler.

ETKİNLİK 1

Dinle. Söylediğim sözcüklerden hangisi farklı sesle başlıyor? Söyle.

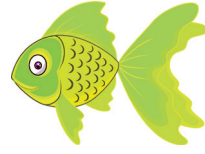

ETKİNLİK 2

Dinle. Söylediğim sözcüklerden hangisi farklı sesle başlıyor? Söyle.

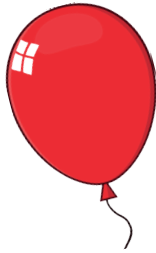
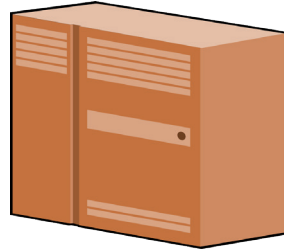

ETKİNLİK 3

Dinle. Söylediğim sözcüklerden hangisi farklı sesle başlıyor? Söyle.

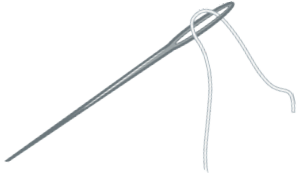
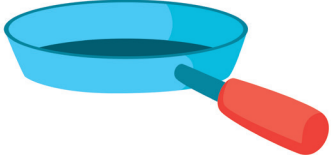

ETKİNLİK 4

Dinle. Söylediğim sözcüklerden hangisi farklı sesle başlıyor? Söyle.

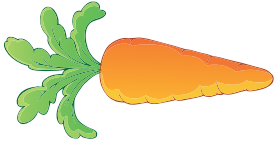

KONU

Sözcüklerin sonundaki sesi ayırt eder.

KAZANIM

Aynı sesle biten sözcüklerin sonunda bulunan sesi söyler.

ETKİNLİK 1

Dinle. Söylediğim sözcükler hangi sesle bitiyor? Söyle.



ETKİNLİK 2

Dinle. Söylediğim sözcükler hangi sesle bitiyor? Söyle.

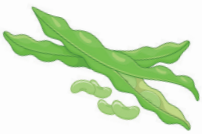
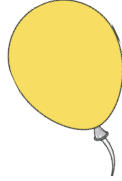
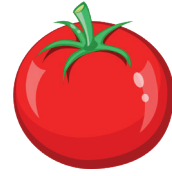

KONU

Sözcüklerin sonundaki sesi ayırt eder.

KAZANIM

Söylenen bir sözcüğün sonunda bulunan sesi söyler.

ETKİNLİK 1

Dinle. Söylediğim sözcük hangi sesle bitiyor? Söyle.

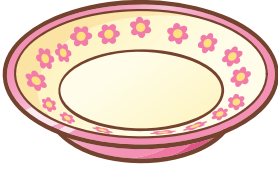
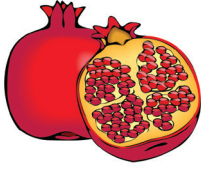

ETKİNLİK 2

Dinle. Söylediğim sözcük hangi sesle bitiyor? Söyle.

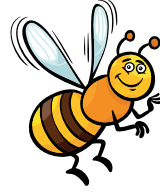

KONU

Sözcüklerin ilk sesini ayırt eder.

KAZANIM

Aynı sesle başlayıp aynı sesle biten sözcükler arasından farklı sesle başlayıp farklı sesle biten sözcükleri söyler.

ETKİNLİK 1

Dinle. Hangi sözcüğün söylenişi farklı? Söyle.

inek itek
isek top

bal bol
tut bil

bak sol
sil sal

ütü üşü
kuş ürü

ETKİNLİK 2

Dinle. Hangi sözcüğün söylenişi farklı? Söyle.

göl gol
tut gel

cem efe
ege ece

tat bak
tut tüt

aca ala
ula aya

KONU

Sözcüklerin sonundaki sesi ayırt eder.

KAZANIM

Aynı sesle biten sözcükler arasından farklı sesle biten sözcüğü söyler.

ETKİNLİK 1

Dinle. Farklı sesle biten sözcüğü söyle.







Dinle. Farklı sesle biten sözcüğü söyle.



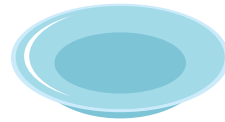
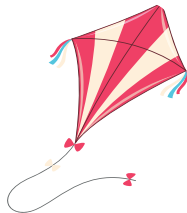



ETKİNLİK 2

Dinle. Farklı sesle biten sözcüğü söyle.



Dinle. Farklı sesle biten sözcüğü söyle.

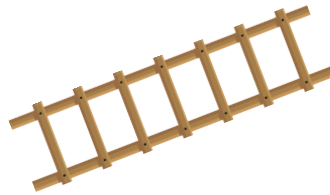

KONU

Sözcüklerin sonundaki sesi ayırt eder.

KAZANIM

Son sesi eksik olarak söylenen bir sözcükte eksik söylenen sesi söyler.

ETKİNLİK 1

Dinle. Söylediğim sözcükte hangi ses eksik? Söyle.

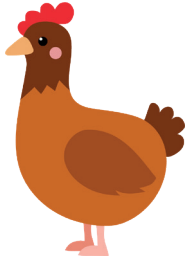

Tavu (k)



Mandalin (a)

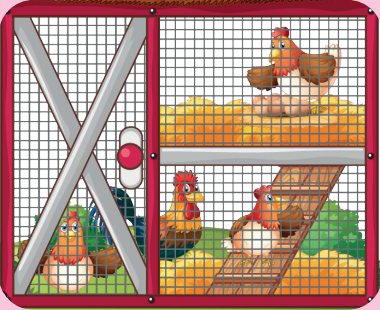

Küme (s)

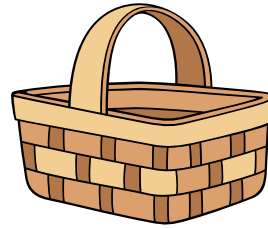

Sepe (t)



Şemsiy (e)



Helikopte (r)

ETKİNLİK 2

Dinle. Söylediğim sözcükte hangi ses eksik? Söyle.



Ağa (ç)



Zar (f)



Horo (z)



Asla (n)

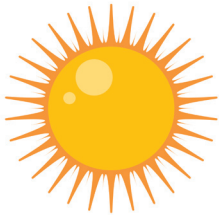

Güne (ş)



Havl (u)



HARF BİLGİSİ



KONU

Aynı olan harfleri eşler.

KAZANIM

Farklı büyük harfler arasından aynı olan büyük harfleri gösterir.

ETKİNLİK 1

A

Yanda gördüğün harfi incele. Aynı olan harfleri işaretle.

B

K

A

A

E

L



ETKİNLİK 2

M

Yanda gördüğün harfi incele. Aynı olan harfleri işaretle.

M

E

R

C

M

A



ETKİNLİK 3

D

Yanda gördüğün harfi incele. Aynı olan harfleri işaretle.

K

E

D

Ğ

D

T



ETKİNLİK 4

E

Yanda gördüğün harfi incele. Aynı olan harfleri işaretle.

E

G

A

E

R

Z



ETKİNLİK 5

u

Yanda gördüğün harfi incele. Aynı olan harfleri işaretle.

K

u

i

P

E

u



KONU

Aynı olan harfleri eşler.

KAZANIM

Farklı küçük harfler arasından aynı olan küçük harfleri gösterir.

ETKİNLİK 1

b

Yanda gördüğün harfi incele. Aynı olan harfleri işaretle.

h

a

b

e

o

b



ETKİNLİK 2

t

Yanda gördüğün harfi incele. Aynı olan harfleri işaretle.

o

b

u

p

t

t



ETKİNLİK 3

r

Yanda gördüğün harfi incele. Aynı olan harfleri işaretle.

m

s

r

i

r

t



ETKİNLİK 4

S

Yanda gördüğün harfi incele. Aynı olan harfleri işaretle.

ü

s

y

ç

z

s



ETKİNLİK 5

f

Yanda gördüğün harfi incele. Aynı olan harfleri işaretle.

a

ı

f

f

h

l



KONU

Aynı olan harfler arasından farklı harfi gösterir.

KAZANIM

Aynı büyük harfler arasından farklı olan büyük harfi gösterir.

ETKİNLİK 1

Harflere bak. Farklı olan harfi işaretle.

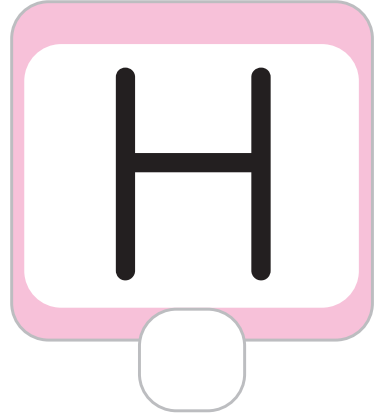
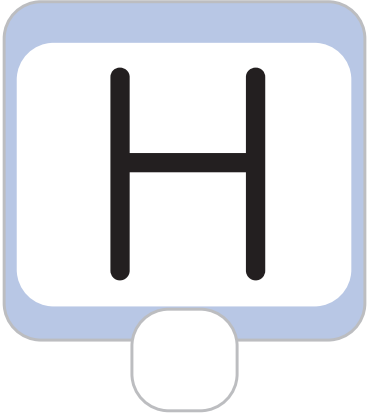

Harflere bak. Farklı olan harfi işaretle.

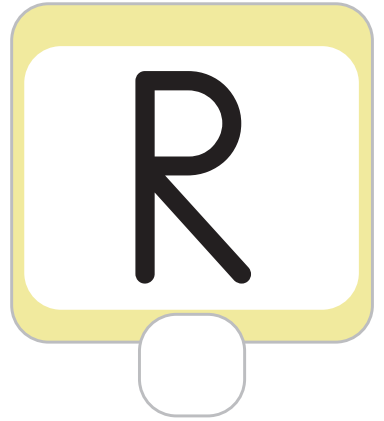

ETKİNLİK 2

Harflere bak. Farklı olan harfi işaretle.

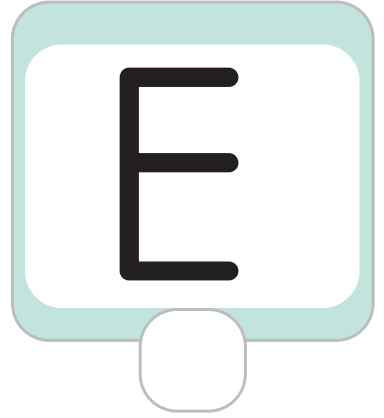
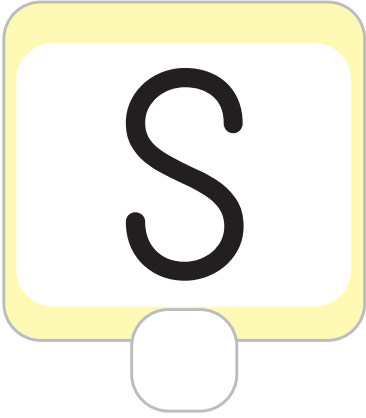

Harflere bak. Farklı olan harfi işaretle.

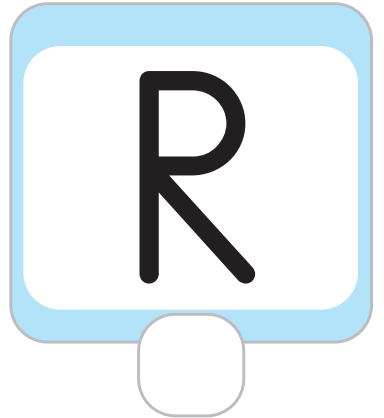
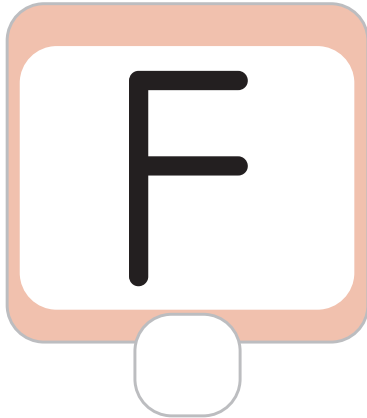
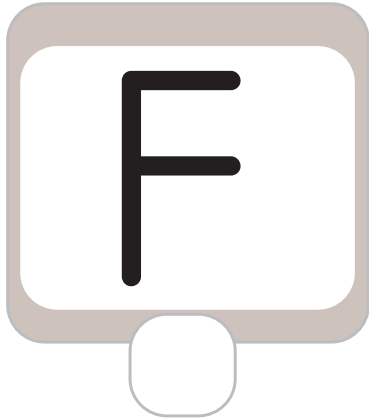

ETKİNLİK 3

Harflere bak. Farklı olan harfi işaretle.

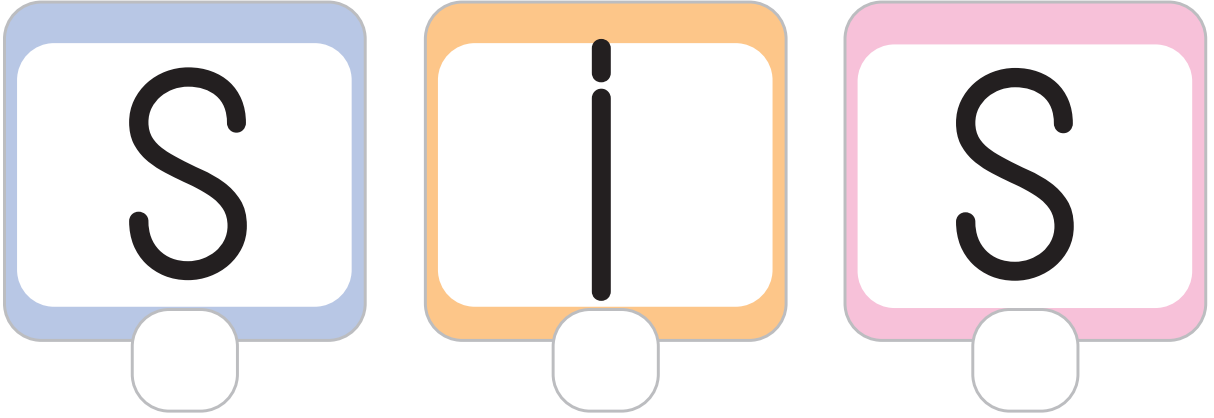

Harflere bak. Farklı olan harfi işaretle.

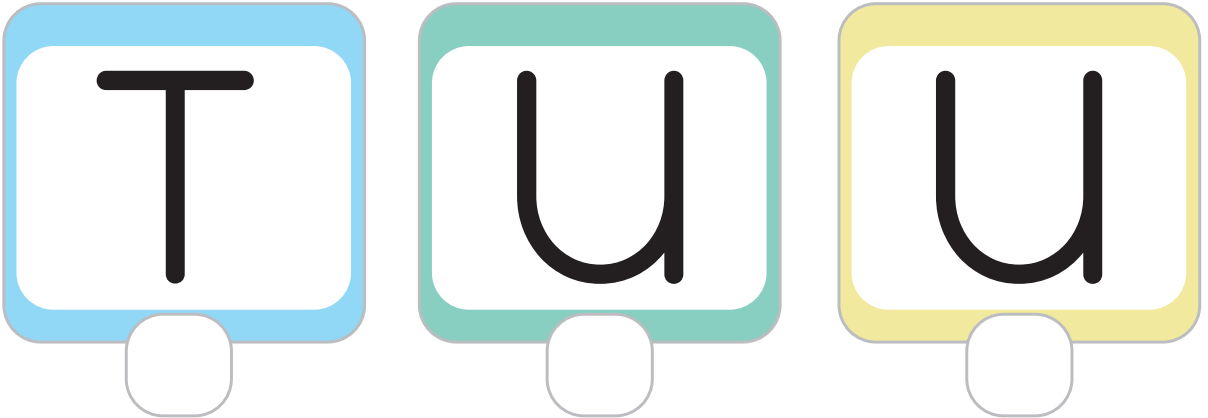

ETKİNLİK 4

Harflere bak. Farklı olan harfi işaretle.

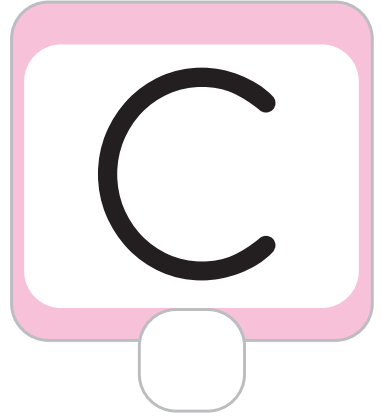
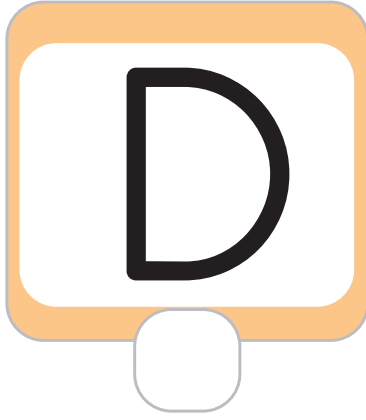
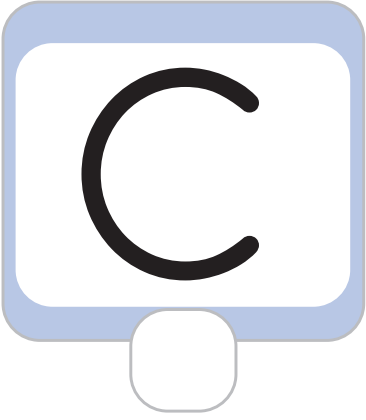

Harflere bak. Farklı olan harfi işaretle.

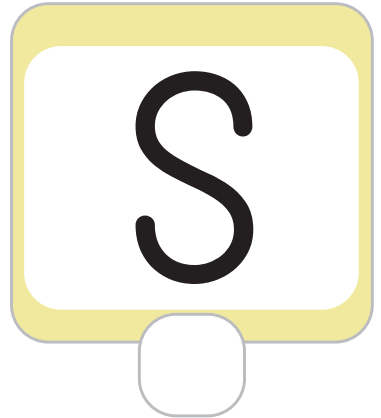
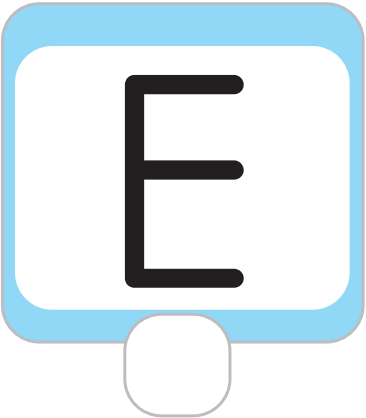

KONU

Aynı olan harfler arasından farklı harfi gösterir.

KAZANIM

Aynı küçük harfler arasından farklı olan küçük harfi gösterir.

ETKİNLİK 1

Harflere bak. Farklı olan harfi işaretle.

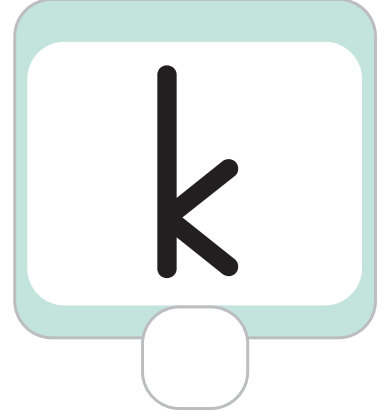
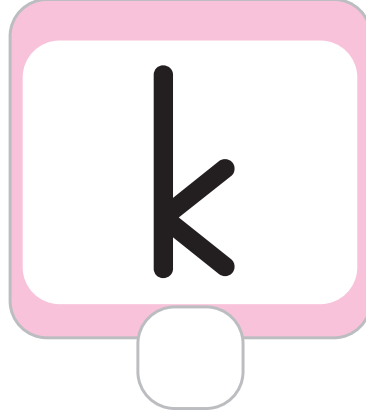
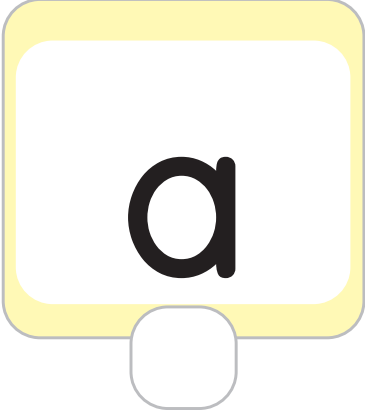

Harflere bak. Farklı olan harfi işaretle.

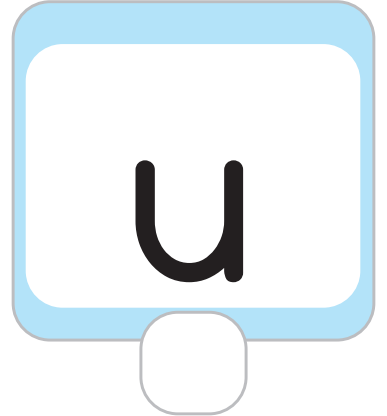
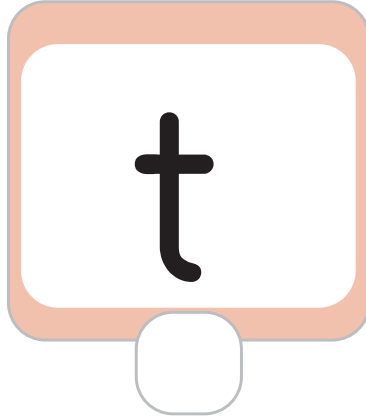
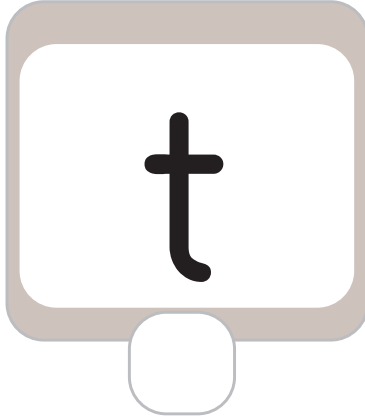

ETKİNLİK 2

Harflere bak. Farklı olan harfi işaretle.

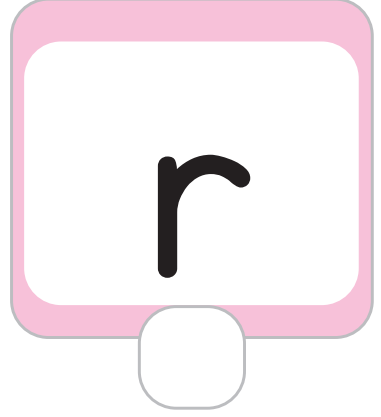
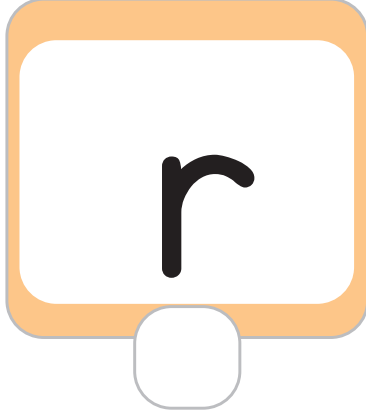
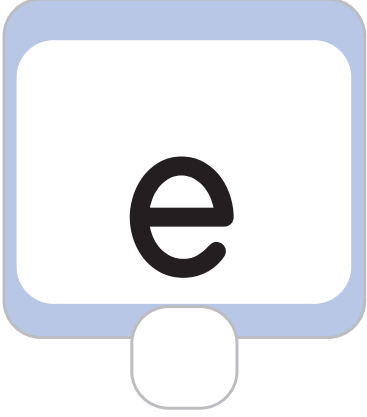

Harflere bak. Farklı olan harfi işaretle.

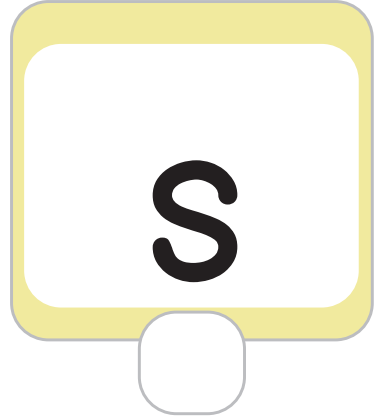
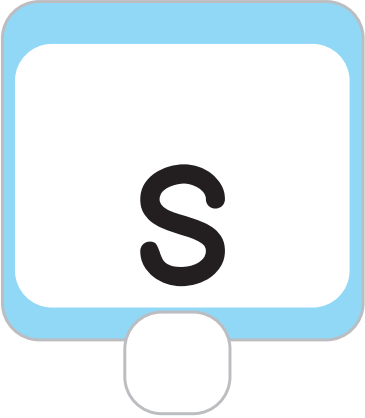

ETKİNLİK 3

Harflere bak. Farklı olan harfi işaretle.

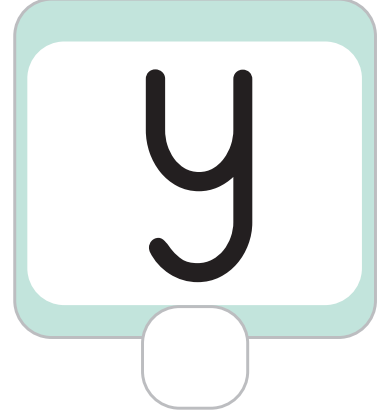
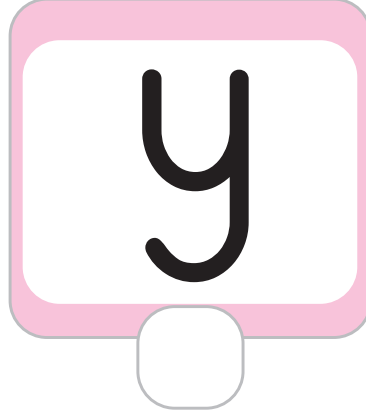
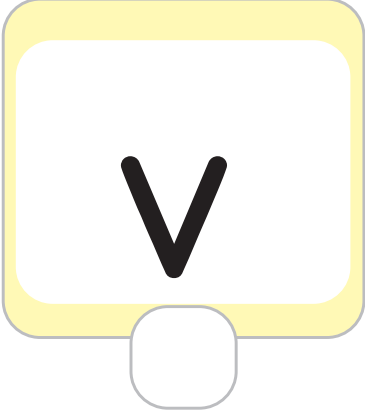

Harflere bak. Farklı olan harfi işaretle.

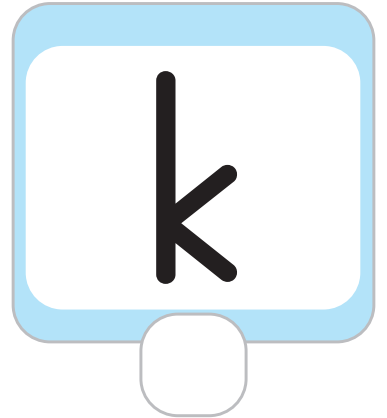
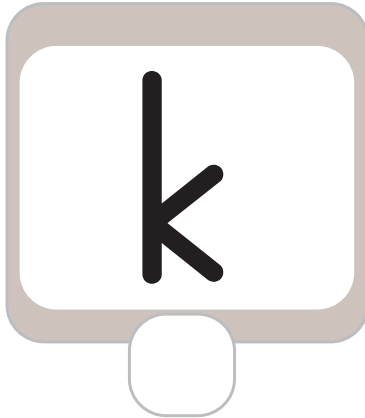

ETKİNLİK 4

Harflere bak. Farklı olan harfi işaretle.



Harflere bak. Farklı olan harfi işaretle.

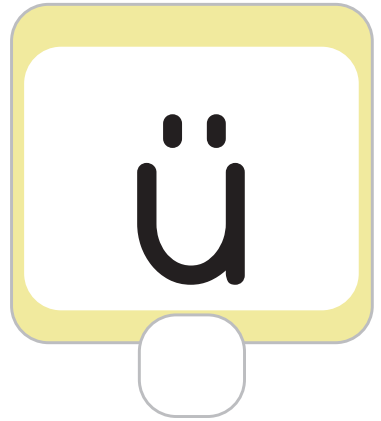
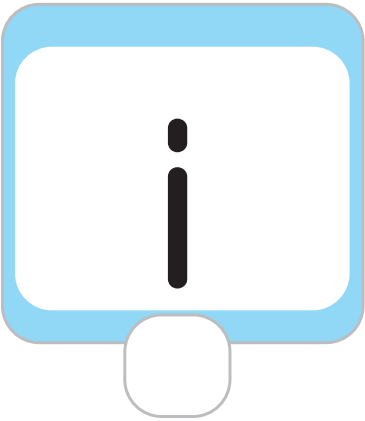

KONU

Aynı olan harfler arasından farklı harfi gösterir.

KAZANIM

Görünüşleri birbirine benzer olan harfler arasından farklı olanı gösterir.

ETKİNLİK 1

Harflere bak. Görünüşü farklı olan harfi işaretle.

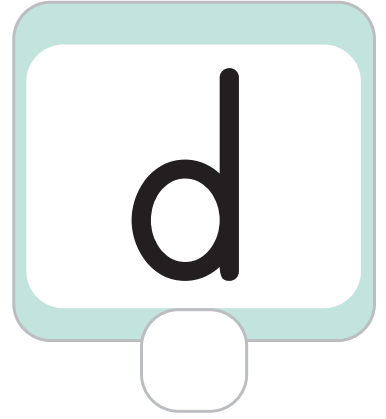
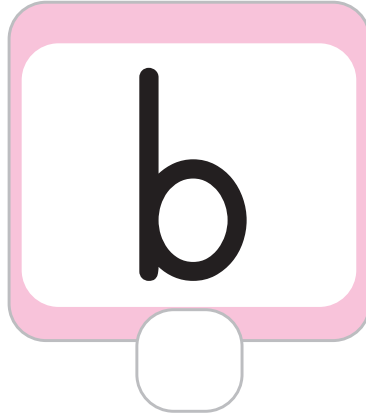
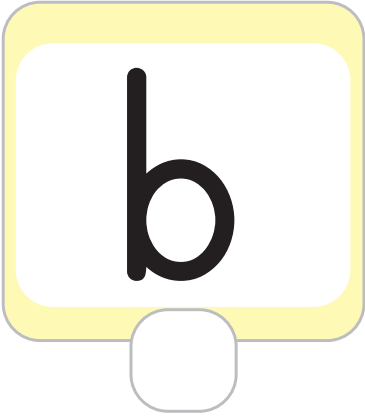

Harflere bak. Görünüşü farklı olan harfi işaretle.

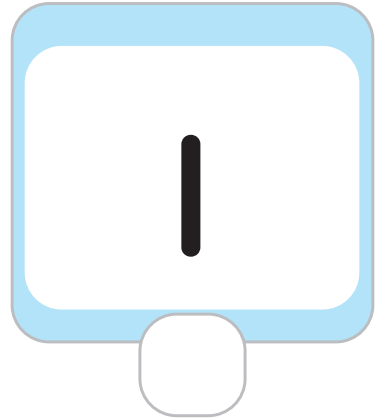
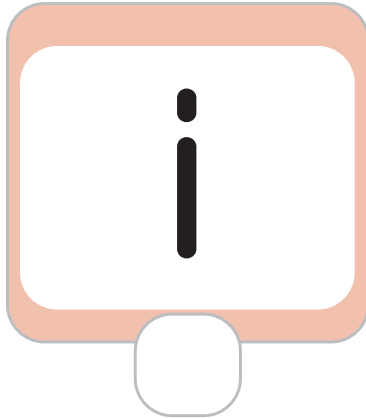
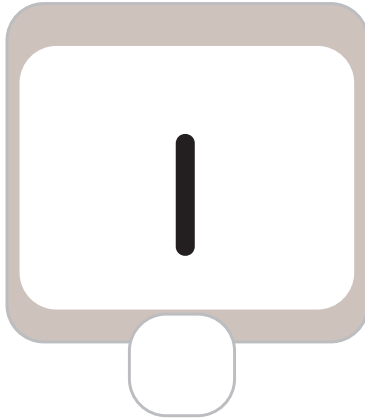

ETKİNLİK 2

Harflere bak. Görünüşü farklı olan harfi işaretle.

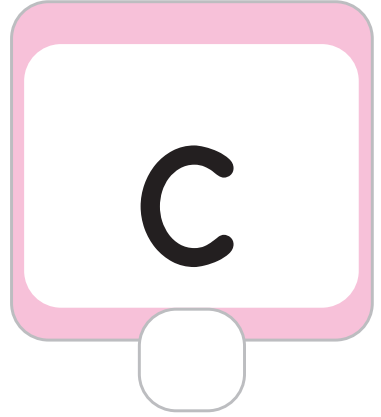
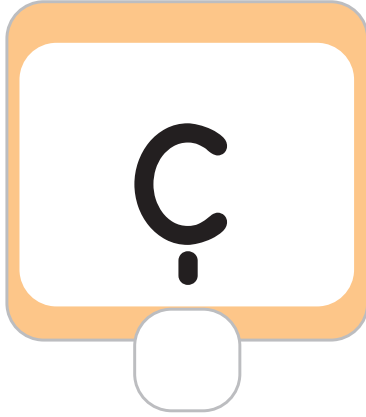
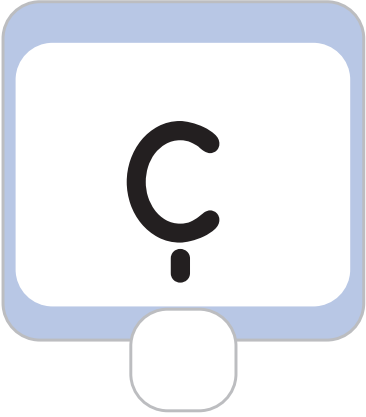

Harflere bak. Görünüşü farklı olan harfi işaretle.

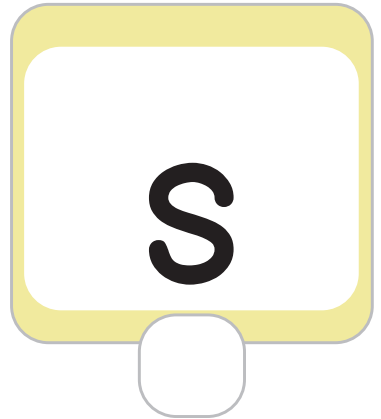
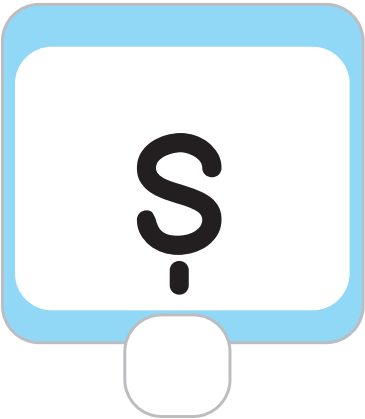

KONU

Büyük ve küçük harfleri gruplar.

KAZANIM

Verilen küçük harfler arasından aynı olan harfleri gruplar.

ETKİNLİK 1

Harfleri incele. Verilen harfler arasından aynı olanları örnekteki gibi boyayarak grupla.

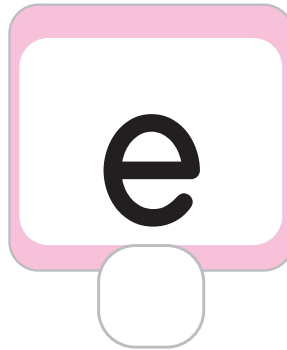
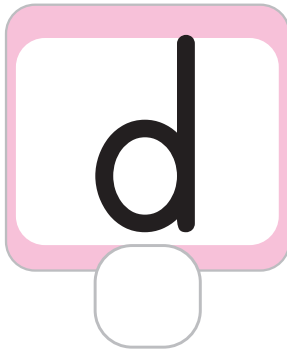
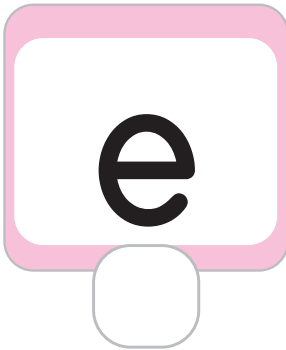
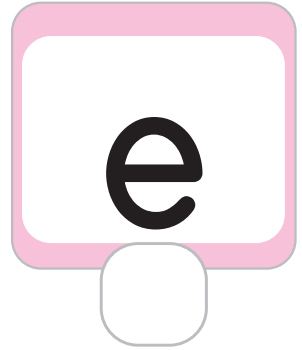
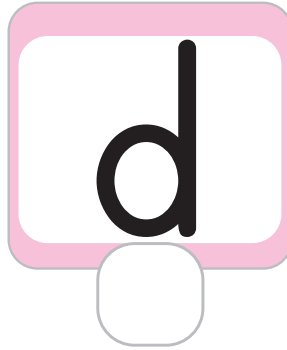
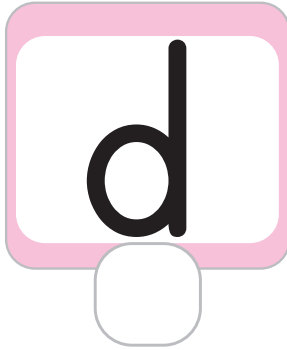
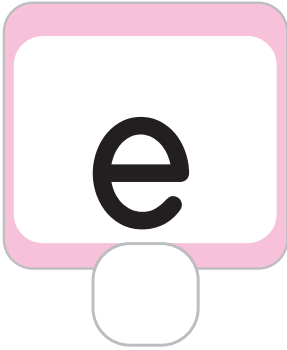
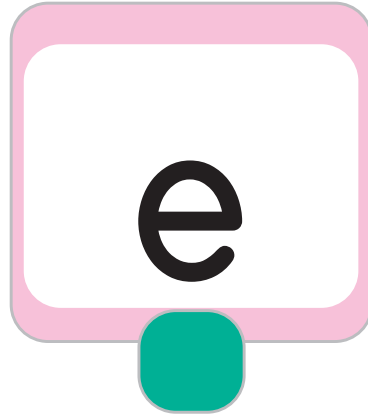
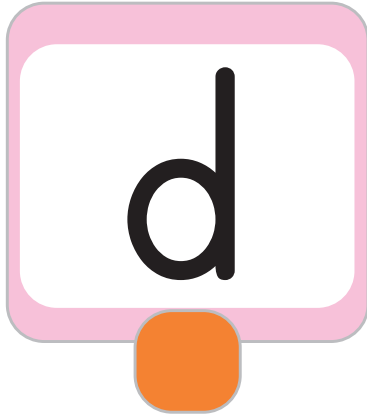

ETKİNLİK 2

Harfleri ince. Verilen harfler arasından aynı olanları örnekteki gibi boyayarak grupla.

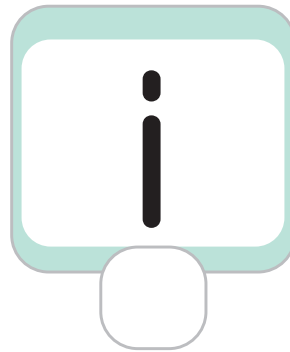
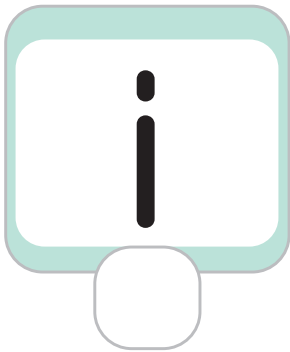
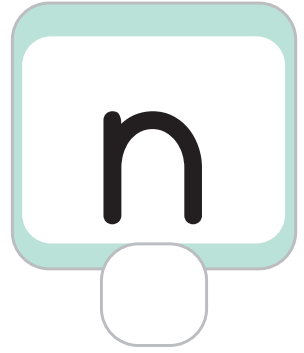
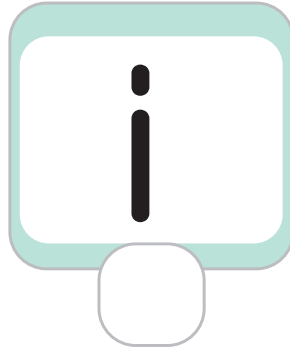
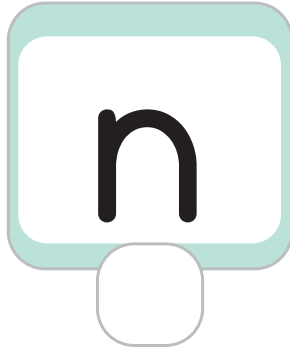
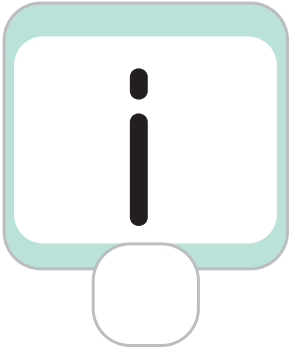
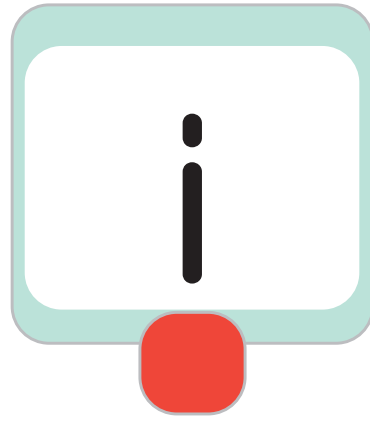

ETKİNLİK 3

Harfleri inceleyin. Verilen harfler arasından aynı olanları örnekteki gibi boyayarak gruplayın.

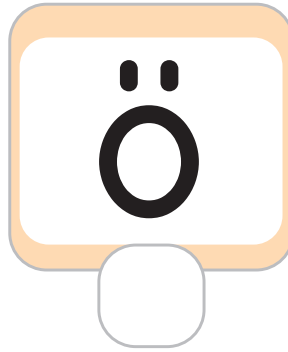
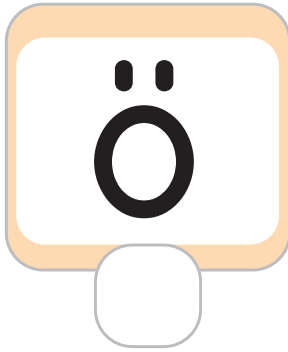
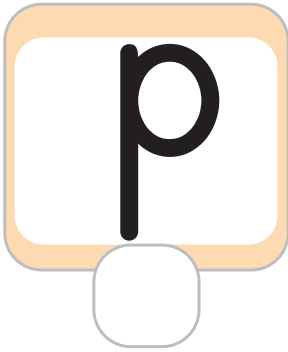
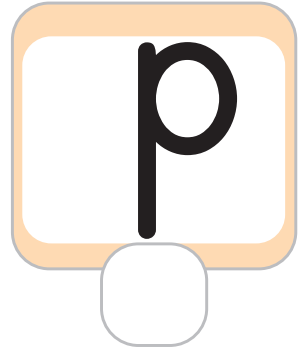
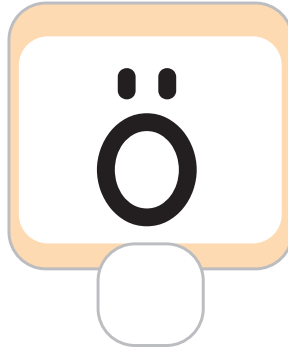
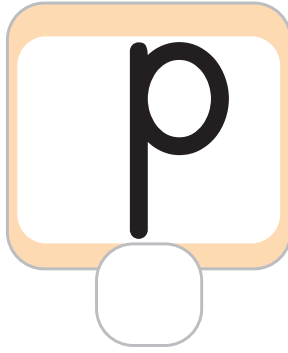
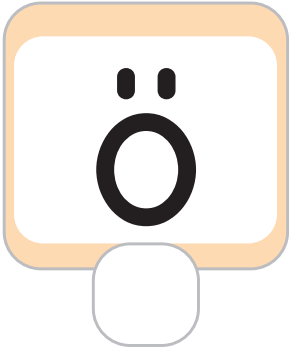
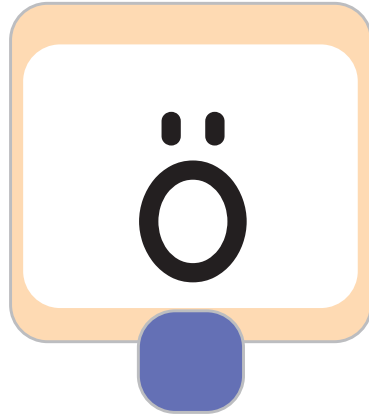
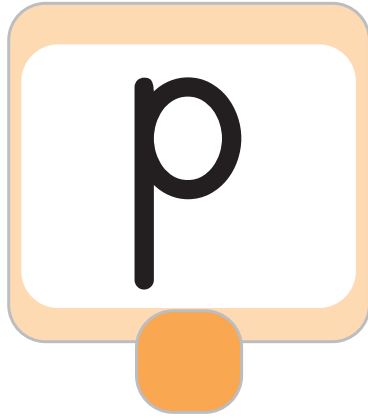

ETKİNLİK 4

Harfleri inceleyin. Verilen harfler arasından aynı olanları örnekteki gibi boyayarak gruplayın.

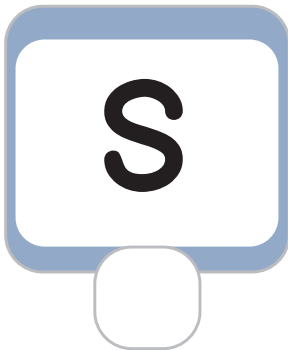
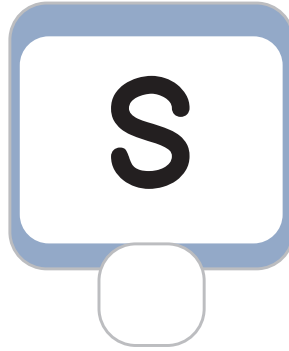
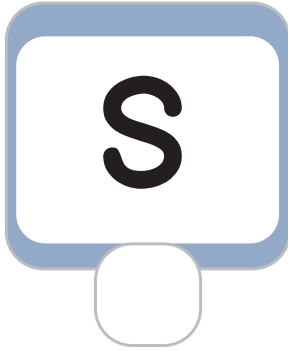

KONU

Büyük ve küçük harfleri gruplar.

KAZANIM

Verilen büyük harfler arasından aynı olan harfleri gruplar.

ETKİNLİK 1

Harfleri incele. Verilen harfler arasından aynı olanları örnekteki gibi boyayarak grupla.

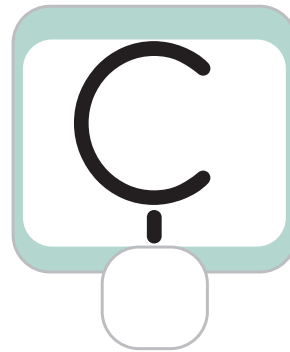
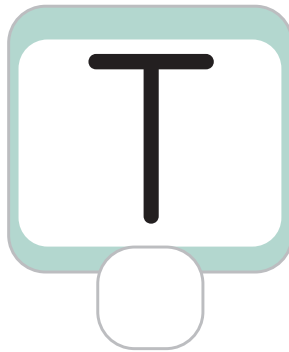
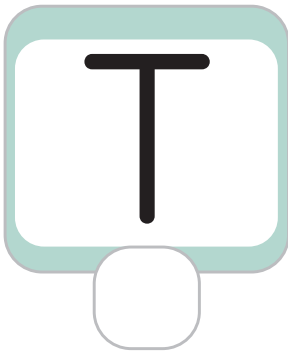
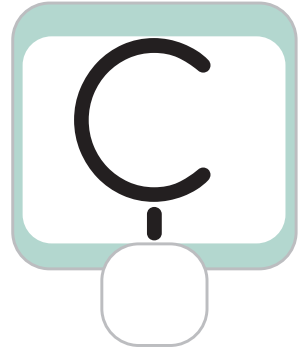
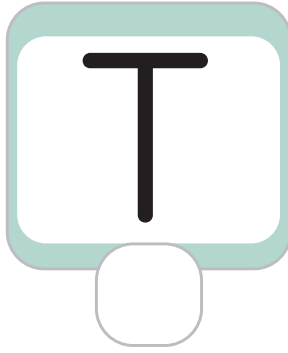
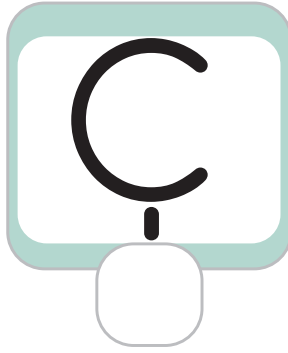
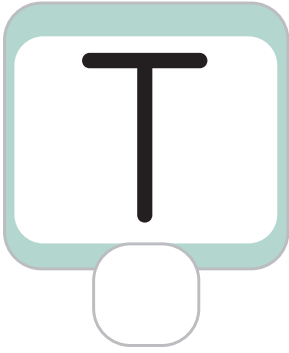
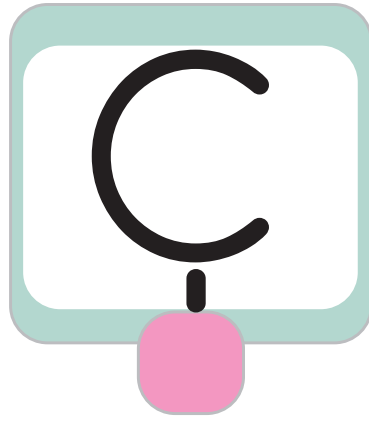
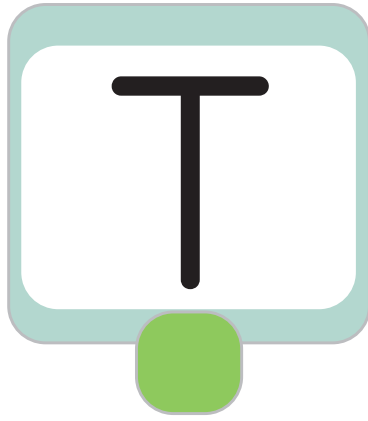

ETKİNLİK 2

Harfleri incele. Verilen harfler arasından aynı olanları örnekteki gibi boyayarak grupla.

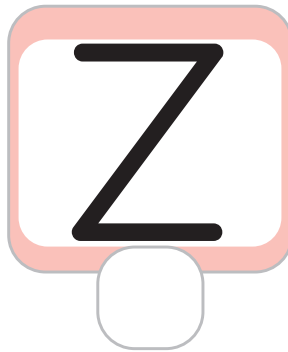
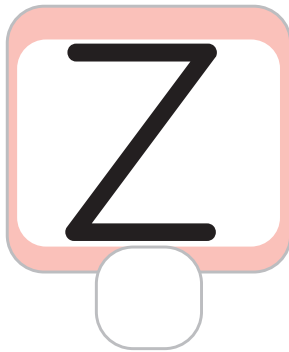
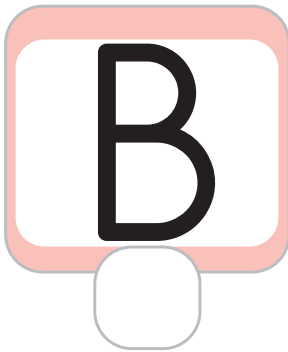
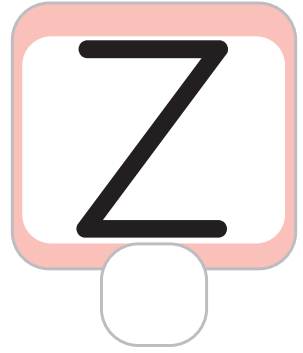
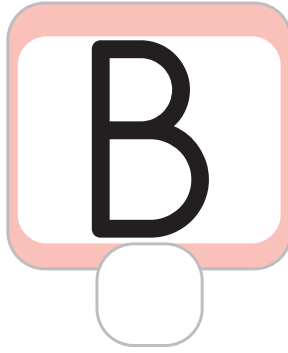
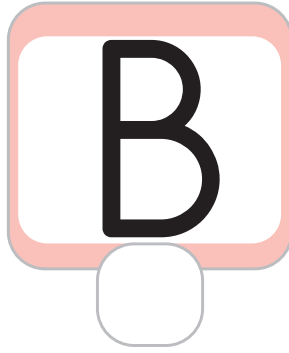
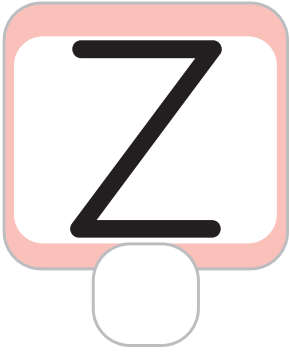
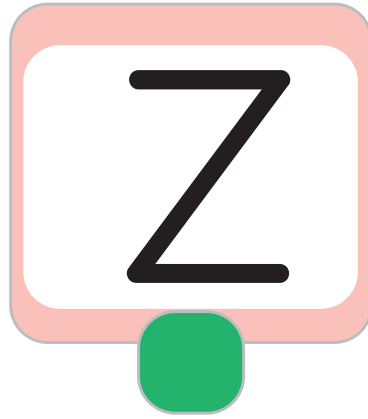
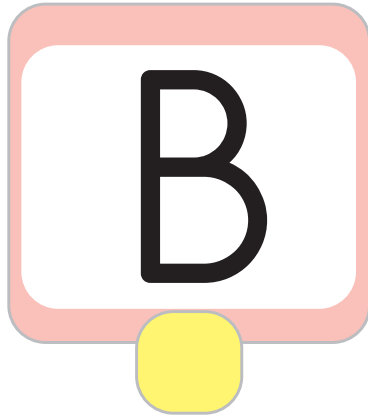

ETKİNLİK 3

Harfleri inceleyin. Verilen harfler arasından aynı olanları örnekteki gibi boyayarak gruplayın.

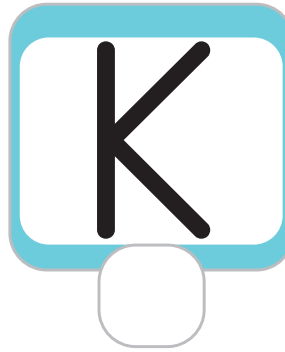
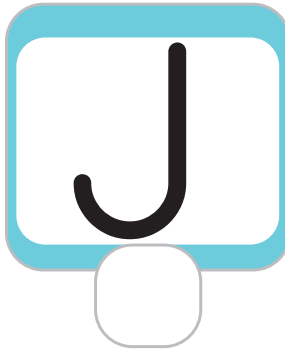
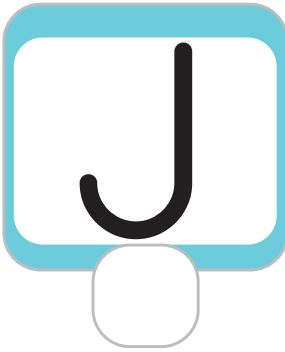
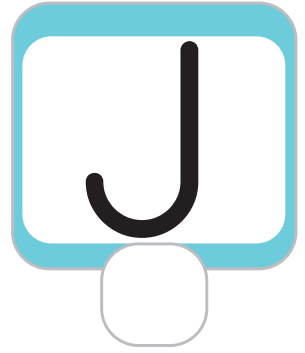
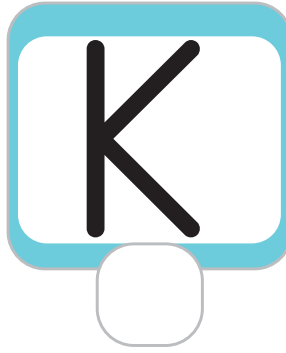
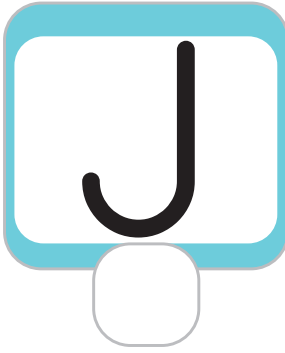
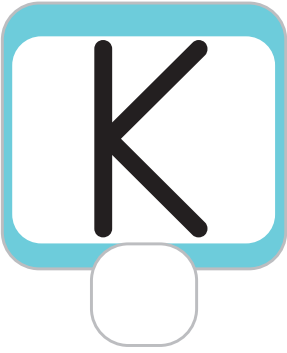
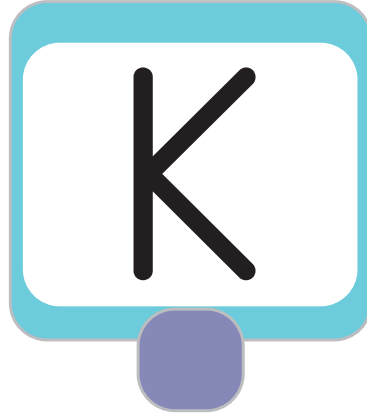
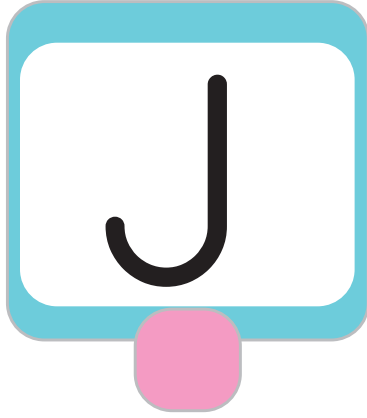

KONU

Büyük ve küçük harfleri gruplar.

KAZANIM

Karışık olarak verilen büyük-küçük harfleri gruplar.

ETKİNLİK 1

Harflere bak. Büyük harfleri kırmızıya, küçük harfleri maviye boya.



h

Y

Ş

B

r

P

n

Ç

T

ETKİNLİK 2

Harflere bak. Büyük harfleri turuncuya, küçük harfleri maviye boya.



V

i

ü

ş

M

a

E

A

ı

ETKİNLİK 3

Harflere bak. Büyük harfleri kırmızıya, küçük harfleri yeşile boya.



a

P

e

H

t

T

o

Ç

K

KONU

Büyük ve küçük harfleri kullanarak çeşitli örüntüler oluşturur.

KAZANIM

Büyük ve küçük harflerle oluşturulmuş bir örüntünün altına aynı örüntüyü oluşturur.

ETKİNLİK 1

Örüntüyü incele. Aynı örüntüyü boş bırakılan yere yaz.

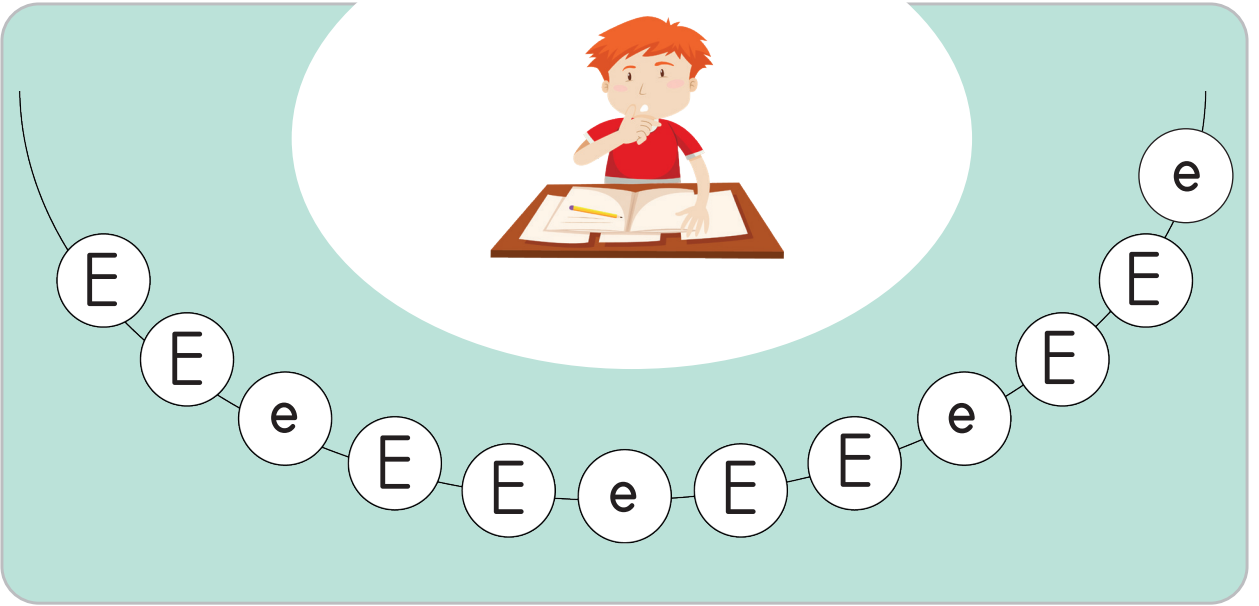

A boy with red hair is sitting at a desk, looking thoughtful with his hand on his chin. In front of him is an open book and a yellow pencil. A string of letters is draped across the desk. The string starts with a large 'E', followed by a large 'E', a small 'e', a large 'E', a large 'E', a small 'e', a large 'E', a large 'E', a small 'e', a large 'E', a large 'E', a small 'e', a large 'E', and ends with a small 'e'.

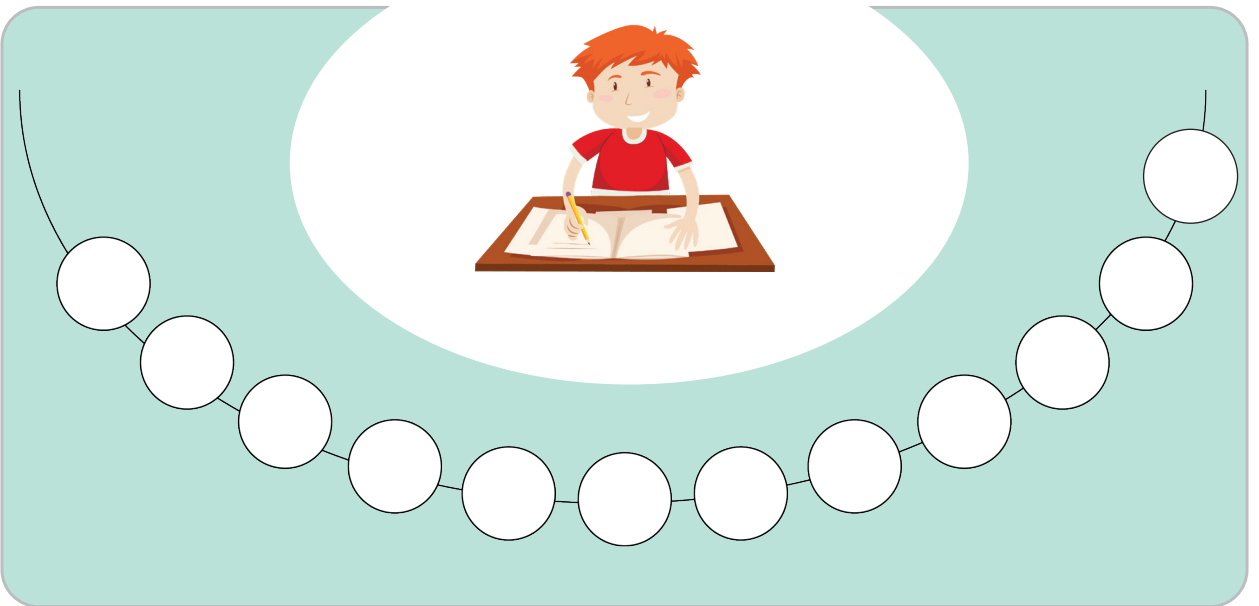

The same boy is sitting at the desk, smiling. The string of letters is now replaced by a string of empty circles, each connected to the next by a small line. The string starts with a large circle, followed by a large circle, a small circle, a large circle, a large circle, a small circle, a large circle, a large circle, a small circle, a large circle, a large circle, a small circle, a large circle, and ends with a small circle.

ETKİNLİK 2

Örüntüyü incele. Aynı örüntüyü boş bırakılan yere yaz.

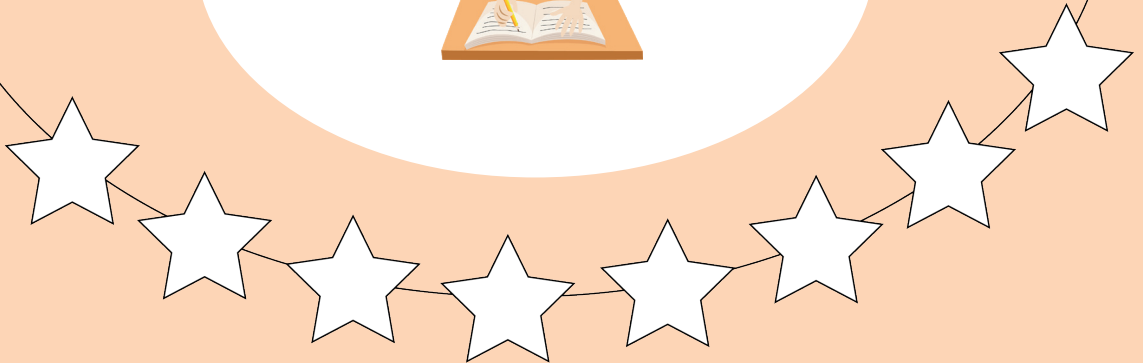

ETKİNLİK 3

Örüntüyü incele. Aynı örüntüyü boş bırakılan yere yaz.

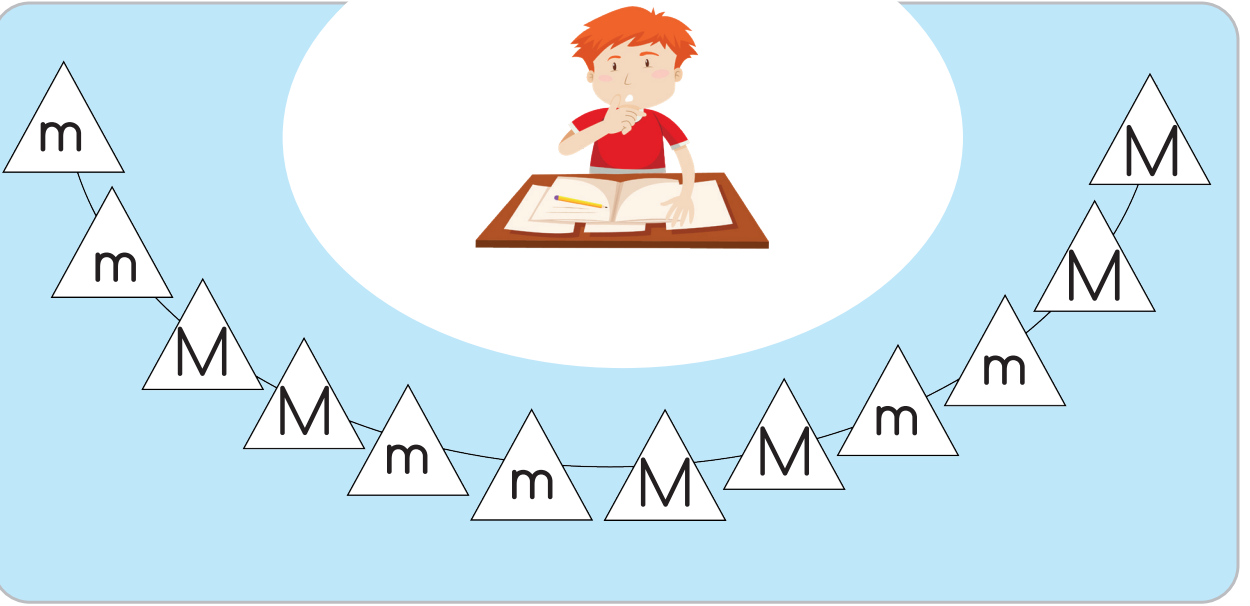

KONU

Büyük ve küçük harfleri kullanarak çeşitli örüntüler oluşturur.

KAZANIM

Büyük ve küçük harflerle oluşturulmuş bir örüntüde eksik bırakılan son ögeyi bulur.

ETKİNLİK 1

Örüntüyü incele. Eksik bırakılan harfi tamamla.

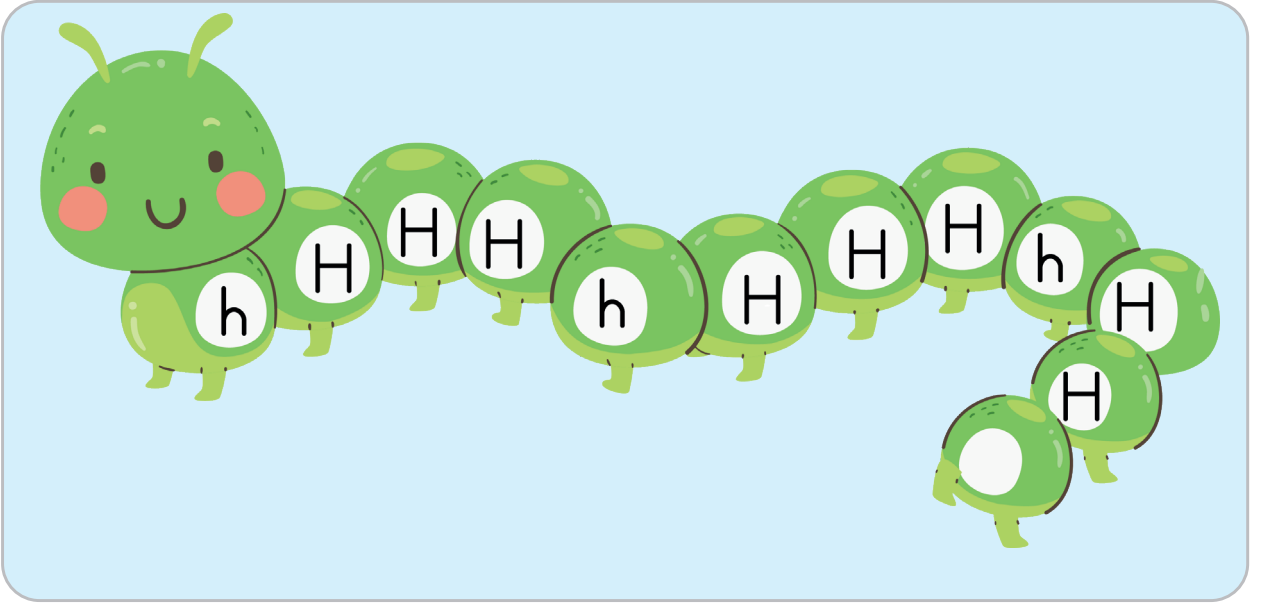

Örüntüyü incele. Eksik bırakılan harfi tamamla.

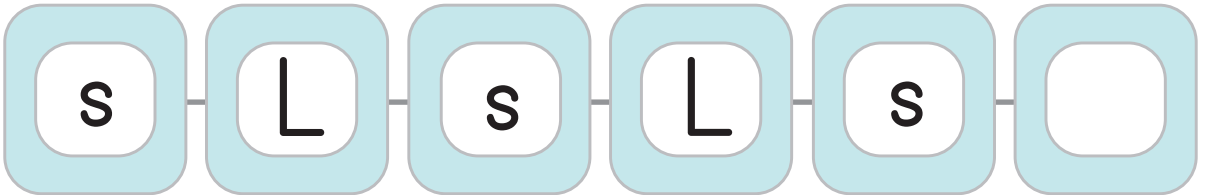

ETKİNLİK 2

Örüntüyü incele. Eksik bırakılan harfi tamamla.

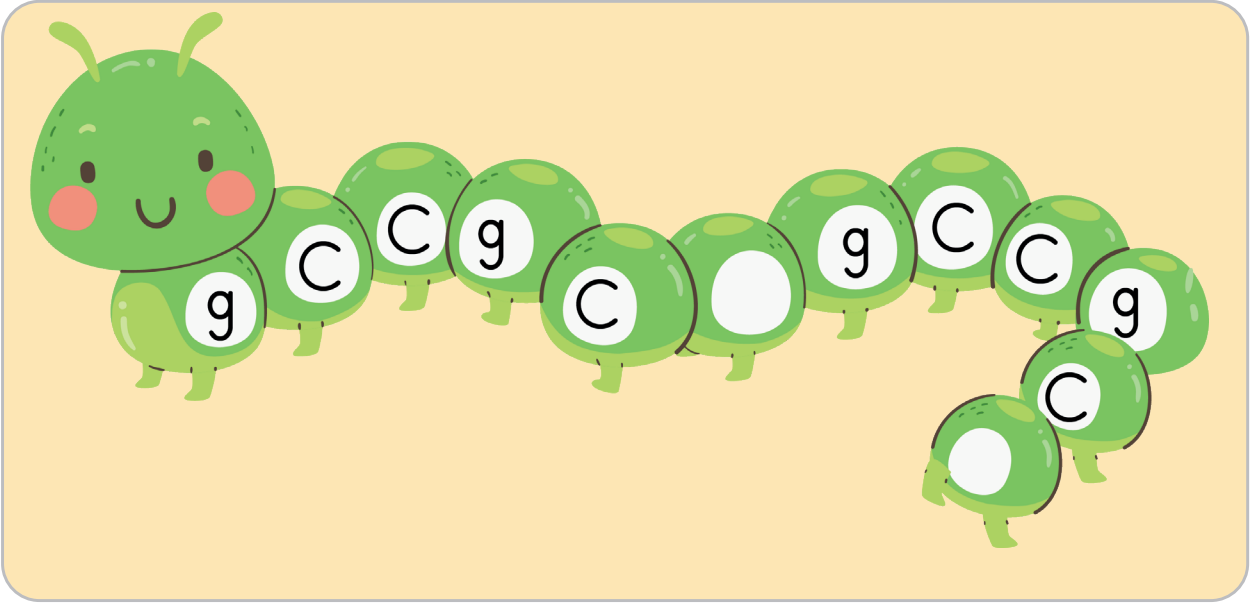

Örüntüyü incele. Eksik bırakılan harfi tamamla.

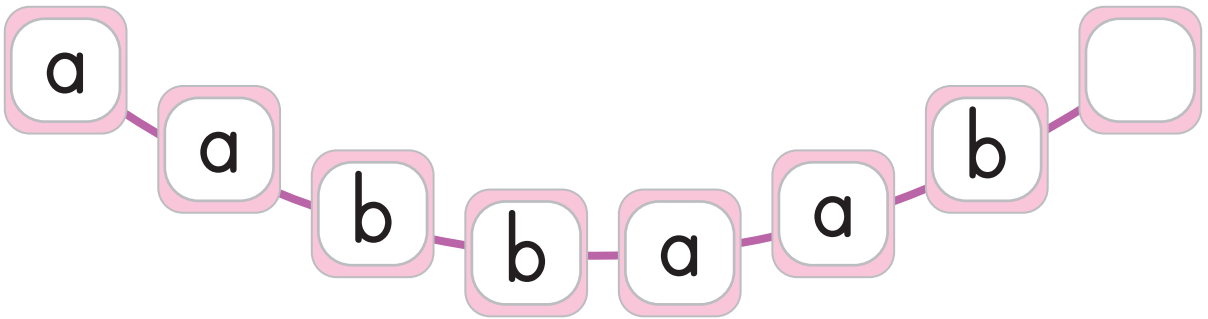

ETKİNLİK 3

Örüntüyü incele. Eksik bırakılan harfi tamamla.

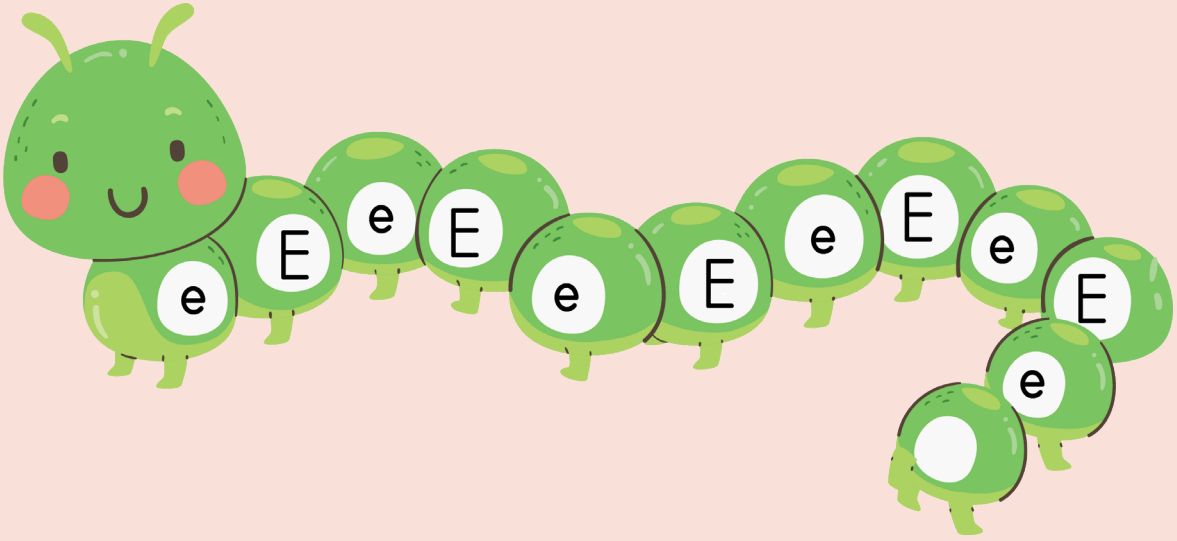

Örüntüyü incele. Eksik bırakılan harfi tamamla.

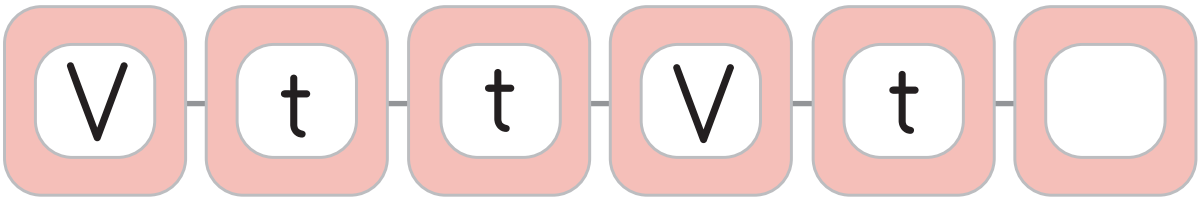

KONU

Büyük ve küçük harfleri kullanarak çeşitli örüntüler oluşturur.

KAZANIM

Büyük ve küçük harflerden oluşturulmuş bir örüntüyü aynı şekilde devam ettirir.

ETKİNLİK 1

Örüntünün kuralına göre boş bırakılan yerlere uygun harfleri yazarak örüntüyü tamamla.

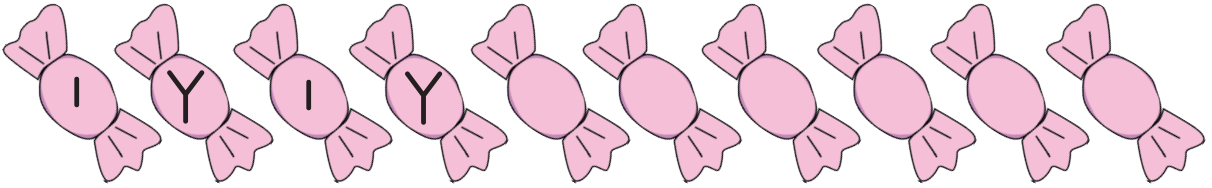

Örüntünün kuralına göre boş bırakılan yerlere uygun harfleri yazarak örüntüyü tamamla.

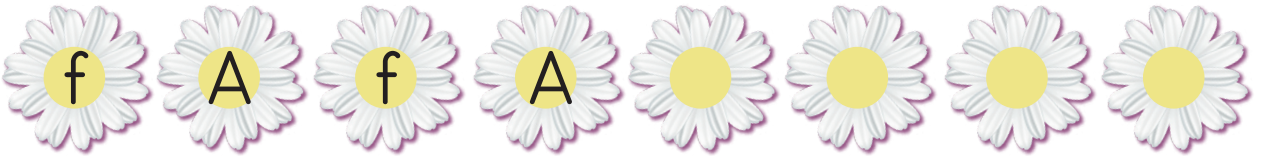

ETKİNLİK 2

Örüntünün kuralına göre boş bırakılan yerlere uygun harfleri yazarak örüntüyü tamamla.

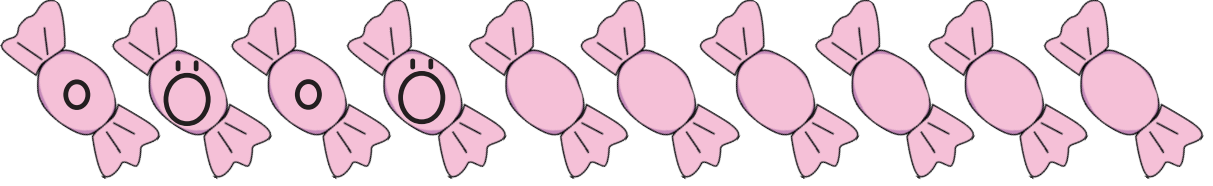

Örüntünün kuralına göre boş bırakılan yerlere uygun harfleri yazarak örüntüyü tamamla.

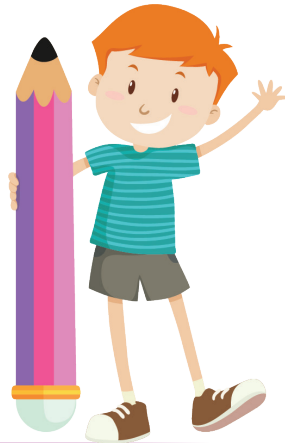
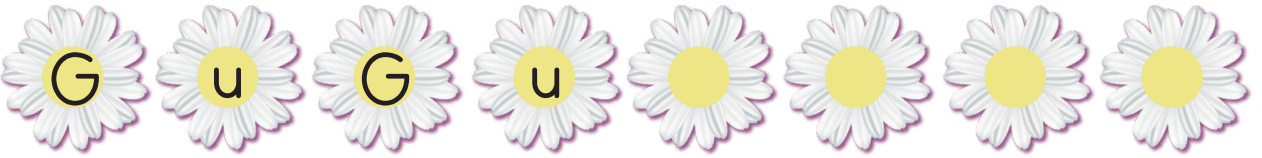

KONU

Büyük ve küçük harfleri kullanarak çeşitli örüntüler oluşturur.

KAZANIM

Büyük ve küçük harflerden oluşturulmuş bir örüntünün ortasında eksik bırakılan ögeyi bulur.

ETKİNLİK 1



Örüntünün kuralını bul. Boş bırakılan yerlere uygun harfleri yaz.



Örüntünün kuralını bul. Boş bırakılan yerlere uygun harfleri yaz.

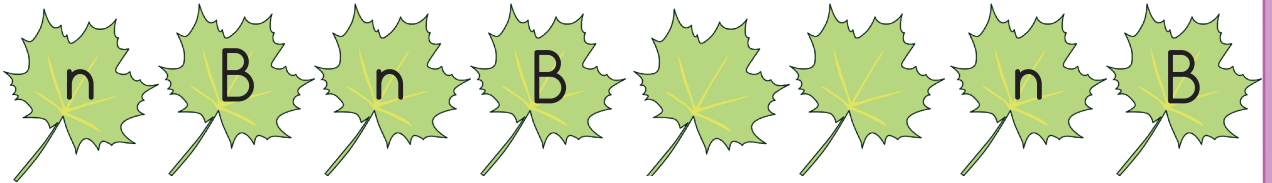

ETKİNLİK 2

Örüntünün kuralını bul. Boş bırakılan yerlere uygun harfleri yaz.



Örüntünün kuralını bul. Boş bırakılan yerlere uygun harfleri yaz.

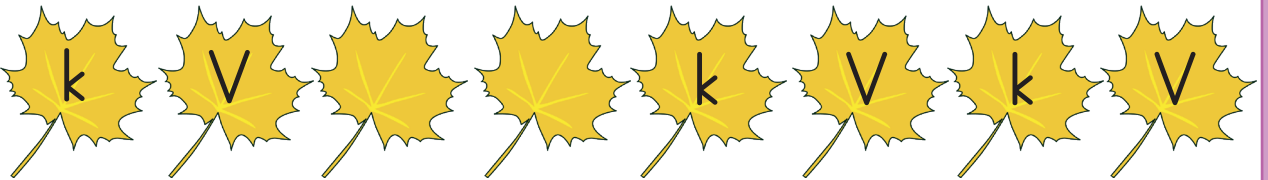

KONU

Birkaç sesi yazılı materyaller içerisinde ayırt eder.

KAZANIM

Sesi söylenen birkaç harfi yazı içinde gösterir.

ETKİNLİK 1

Sözcüklere bak ve öğretmenini dinle. 'l' sesini ve 'ı' sesini göster.

kalem



iğne



erik



leylek



ekin



ETKİNLİK 2

Sözcüklere bak ve öğretmenini dinle. 'm' sesini ve 'a' sesini göster.

mavi



balık

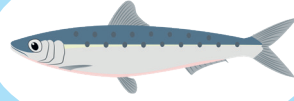

elbise



kamp



badem



ETKİNLİK 3

Cümlelere bak ve öğretmenini dinle. 's' sesini ve 'n' sesini göster.

Yavru ördekler annelerinin arkasından koştular.

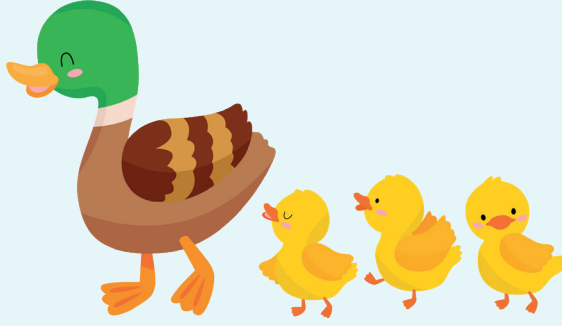

Sabah uyanır uyanmaz yüzümü yıkarım.



Derslerini çok dikkatli dinlemelisin.



ETKİNLİK 4

Metne bak ve öğretmenini dinle. 'i' sesini ve 'k' sesini göster.

Yaralı Köpek

Kardeşimle markete giderken yolda yaralı bir köpek gördük. Onu hemen mahalledeki veterinere götürdük. Veteriner İrfan amca köpeği tedavi etti. Annem köpeğin bizimle birlikte kalabileceğini söyledi. Köpeğimize Lokum ismini verdik.



ETKİNLİK 5

Metne bak ve öğretmenini dinle. 'e' sesini ve 'd' sesini göster.

Ege'nin Cıvcıvı

Yaz tatilinde Ege köye dedesinin yanına gitti. Dedesi Ege'ye sarı küçük bir cıvcıv almıştı. Ege her sabah kümese giderek cıvcıvını besledi.



KONU

Birkaç sesi yazılı materyaller içerisinde ayırt eder.

KAZANIM

Birkaç harf yazı içinde gösterildiğinde sesletir.

ETKİNLİK 1

Cümlelere bak ve dinle. Farklı renkte yazılan harfleri söyle.

- İlbaharda yapraklar yeşerir.
- Kahvaltıda süt içerim.
- Yeni kalemlerim çok güzel.
- Kardeşimle parka gittik.
- Beril bize oyun oynamaya gelecek.

ETKİNLİK 2

Cümlelere bak ve dinle. Farklı renkte yazılan harfleri söyle.

- Tiyatroya gitmek için sabah erkenden kalktı.
- Tüm ödevini dikkatle hazırladı.
- Kahvaltı yaptığında yumurtanı bitirmeyi unutma.
- Ellerinizi sık sık yıkaman gerekli.
- Köpeğini her akşamüstü parka yürüyüşe çıkarırdı.

ETKİNLİK 3

Cümlelere bak ve dinle. Farklı renkte yazılan harfleri söyle.

- Başarılı olmanın sırrı, planlı ve düzenli olmaktan geçer.
- Tüm aileyi bir arada görmek çok güzeldi.
- Cuma günü ağabeyimin mezuniyeti için İzmir'e gideceğiz.
- Yaşlı insanlara ev işlerinde yardımcı olmamız gerekir.
- Yağmurda kalınca tüm kıyafetleri sıırıslam olmuş.

ETKİNLİK 4

Metne bak ve dinle. Farklı renkte yazılan harfleri söyle.

- Anıl sabah erkenden uyandı. Elini yüzünü yıkadı. Annesi seslenince kahvaltısını yapmak için mutfığa gitti.



- Annesi Anıl'a ekmek kızarttı. Anıl ekmeğin yanında peynir, zeytin ve yumurta yedi. Kahvaltıdan sonra dişlerini fırçaladı.



- Okul servisi geldi. Anıl çantasını aldı. Ayakkabılarını giydi. Servise bindi ve okula gitti.





YAZMAYA HAZIRLIK



KONU

Yazı araç gereçlerini tanır.

KAZANIM

Adı söylenen yazı araç gerecini gösterir.

ETKİNLİK 1

Aşağıdaki görseller arasından kalemi işaretle.



Aşağıdaki görseller arasından defteri işaretle.



Aşağıdaki görseller arasından silgiyi işaretle.



Aşağıdaki görseller arasından kalemıraşı işaretle.

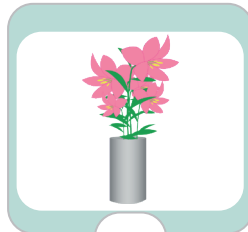

ETKİNLİK 2

Aşağıdaki görseller arasından kalemleri işaretle.



Aşağıdaki görseller arasından defterleri işaretle.



ETKİNLİK 3

Aşağıdaki görseller arasından silgileri işaretle.



Aşağıdaki görseller arasından kalemıraşları işaretle.



ETKİNLİK 4

Aşağıdaki ifadeleri uygun görsellerle eşleştir.

Hangisiyle yazı yazarsın?

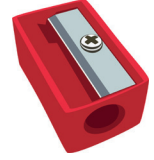

Yazı yazarken yaptığın yanlışları hangisiyle silersin?



Hangisinin üzerine yazı yazarsın?



Kaleminin ucunu hangisiyle açarsın?

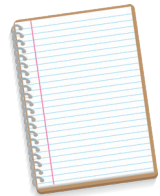

ETKİNLİK 5

Aşağıdaki yazı araç ve gereçlerini belirtilen renklere boy.

Kalem: ■

Defter: ■

Kalemıraş: ■

Silgi: ■

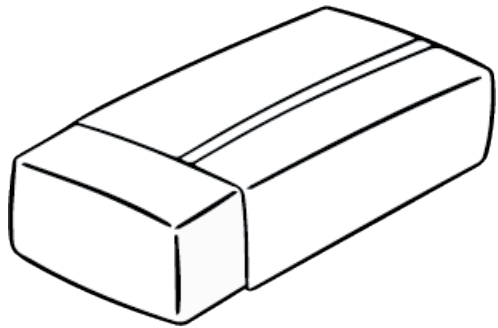
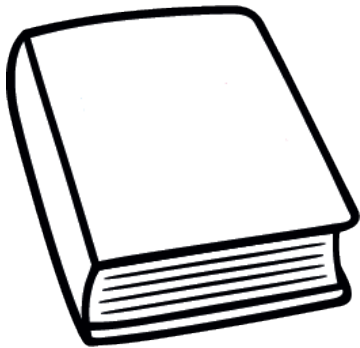
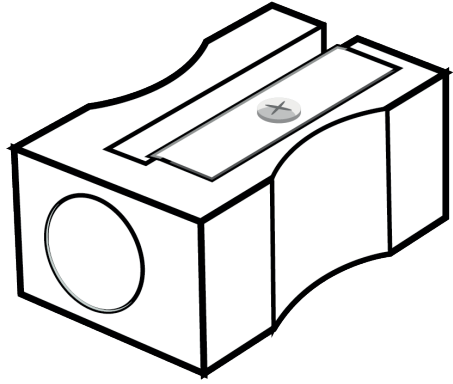
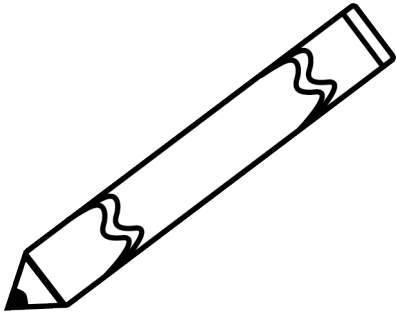

KONU

Yazı araç gereçlerini tanıır.

KAZANIM

Gösterilen yazı araç gerecinin adını söyler.

ETKİNLİK 1

Aşağıdaki yazı araç ve gereçlerinin isimlerini söyle.

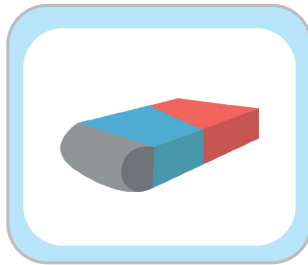
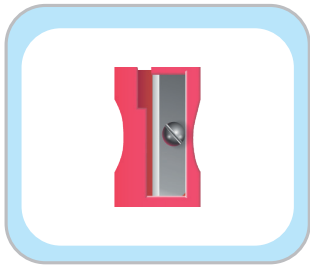
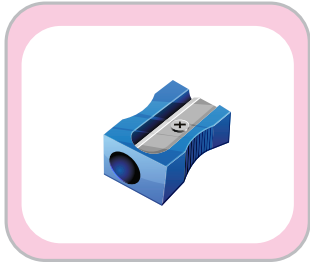
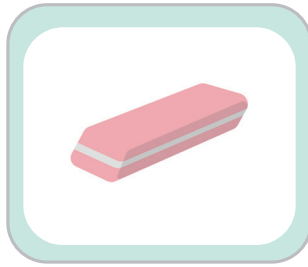
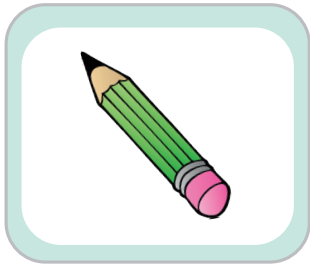

ETKİNLİK 2

1. Aşağıdaki öğrencinin masasında yazı yazarken kullanılan araç gereçlerden hangilerinin olduğunu söyle.



2. Yukarıdaki öğrencinin masasında yazı araç ve gereçlerinden hangilerinin eksik olduğunu söyle.

KONU

Yazı araç gereçlerini uygun şekilde kullanır.

KAZANIM

Kalemi uygun şekilde tutar.

ETKİNLİK 1

Yazı yazarken kalemi aşağıdakilerden hangisi gibi tutmalıyız? İşaretle.



Aşağıdakilerden hangisi yanlış kalem tutuş şeklidir? İşaretle.

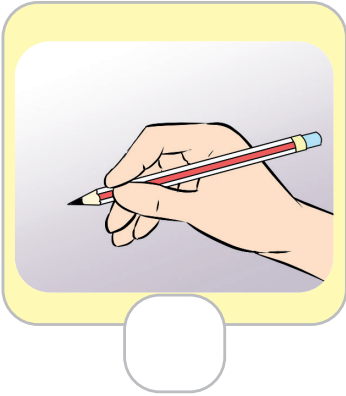

ETKİNLİK 2

Kalemimi doğru bir şekilde tutarak aşağıdaki öğrencinin çantasına giden yolu çiz.



KONU

Yazı araç gereçlerini uygun şekilde kullanır.

KAZANIM

Kâğıdı doğru şekilde tutar.

ETKİNLİK 1

Yazı yazarken kâğıdı aşağıdakilerden hangisi gibi tutmalıyız? İşaretle.



Yazı yazarken nasıl oturmalıyız? İşaretle.



KONU

Yazı araç gereçlerini uygun şekilde kullanır.

KAZANIM

Silgiyi uygun şekilde kullanır.

ETKİNLİK 1

Aşağıdaki arının çiçeğe giderken kullanacağı yolu çiz. Yolu çizerken girdiğin yanlış yolları silgiyi kullanarak sil.

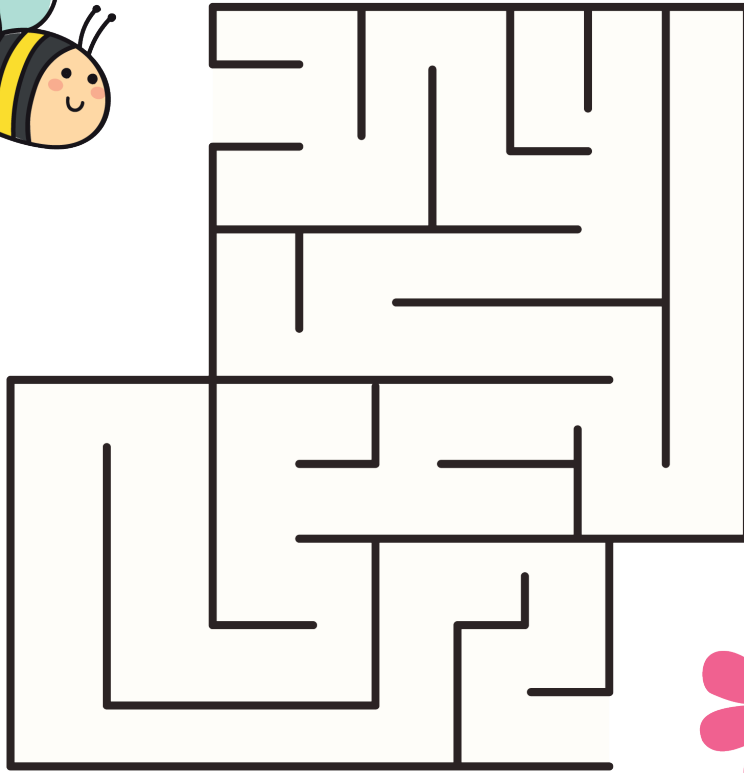
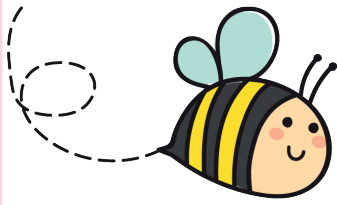

ETKİNLİK 2

Aşağıdaki şekillerin üzerinden kaleminle geç. Ardından silginle sil.

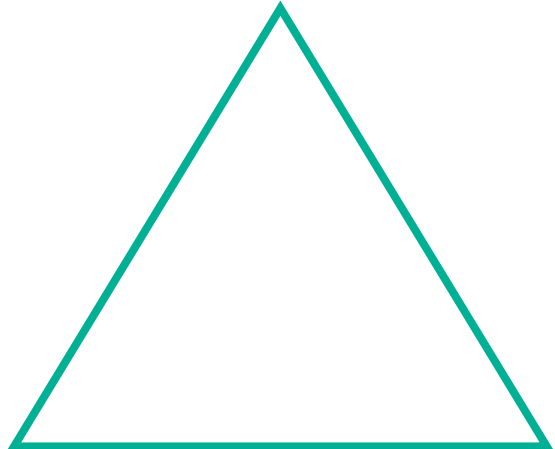
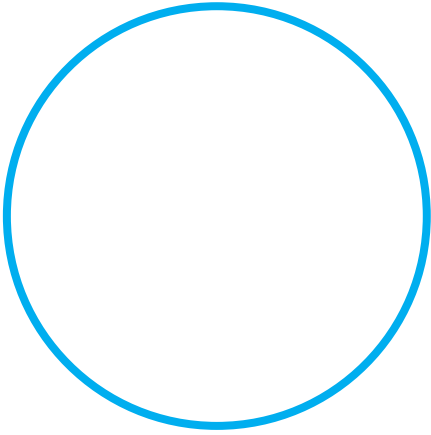

KONU

Yazı araç gereçlerini uygun şekilde kullanır.

KAZANIM

Kalemi kalemtırış ile açar.

ETKİNLİK 1

Aşağıdaki durumlardan hangisinde kalemtırış kullanmak gerekir? İşaretle.

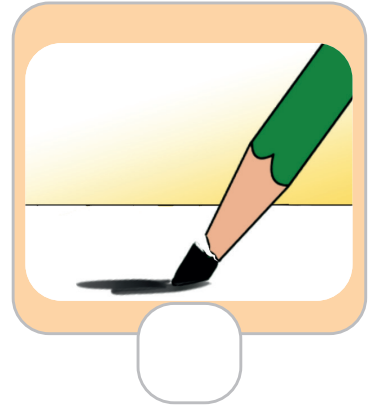
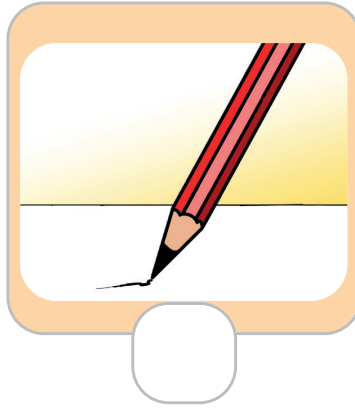
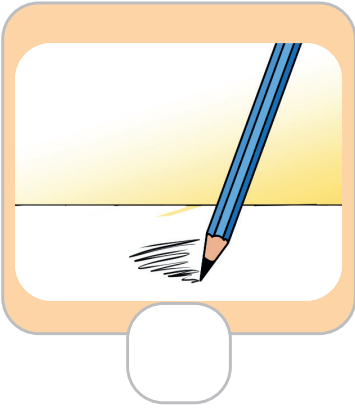

Aşağıdaki kalemlerden hangisinin ucunu açmak gerekir? İşaretle.



ETKİNLİK 2

Aşağıdaki boyama sayfasını boya. Boyama bittikten sonra uçları küçülen veya kırılan boya kalemlerini kalemıraş kullanarak aç.

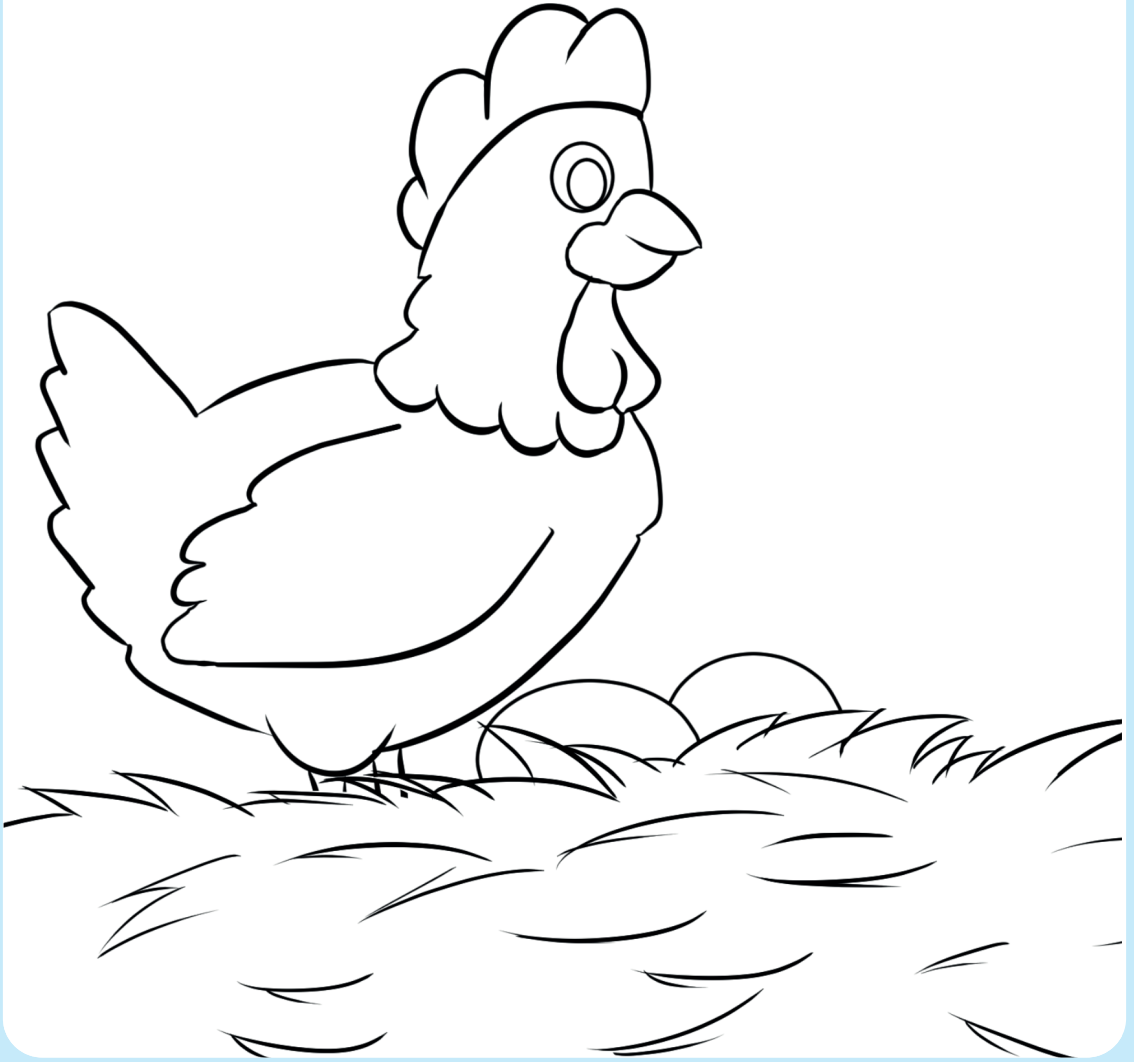

ETKİNLİK 3

Kaleminin ucunu açtıktan sonra aşağıdaki noktaları birleştir ve resmi boya.

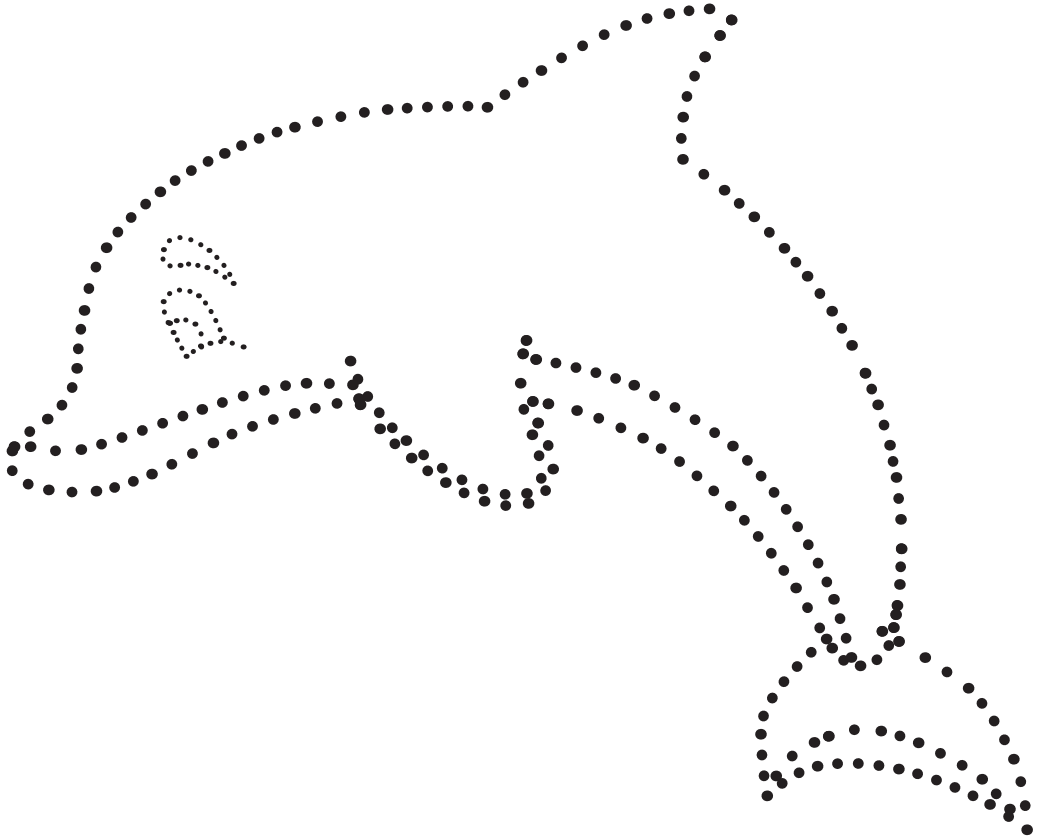

KONU

Yazı araç gereçlerini temiz ve düzenli kullanır.

KAZANIM

Yazı araç gereçlerini temiz ve düzenli kullanmanın önemini fark eder.

ETKİNLİK 1

Aşağıdaki defterlerden hangisinin üzerine yazı yazmak daha kolay olur? İşaretle.

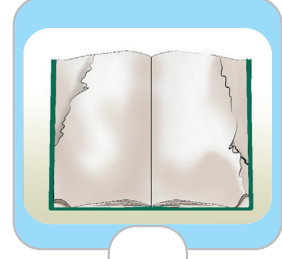
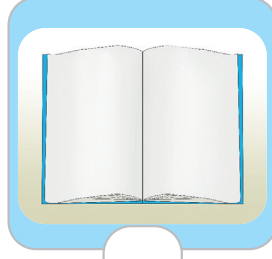
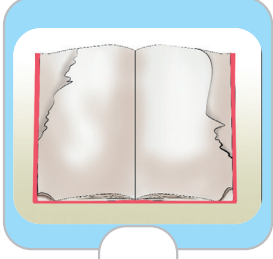

Aşağıdaki kalemlerden hangisi doğru kullanılmıştır? İşaretle.

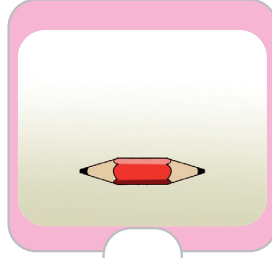

Silgiyi aşağıdaki şekillerden hangisi gibi kullanmak doğrudur? İşaretle.



Aşağıdaki kalemlerden hangisinin ucu doğru açılmıştır? İşaretle.

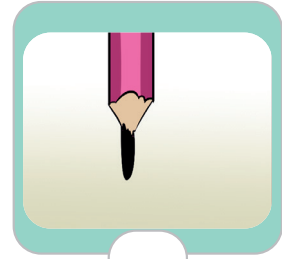
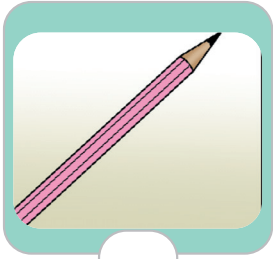

ETKİNLİK 2

Aşağıdaki masalardan hangisinin üzerinde ders çalışmak daha kolay olur? İşaretle.

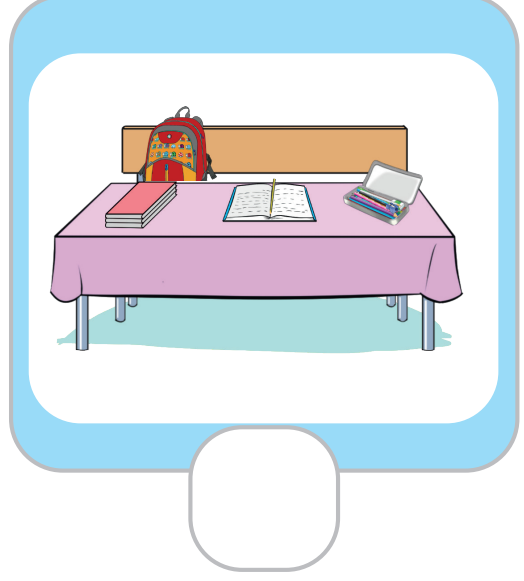
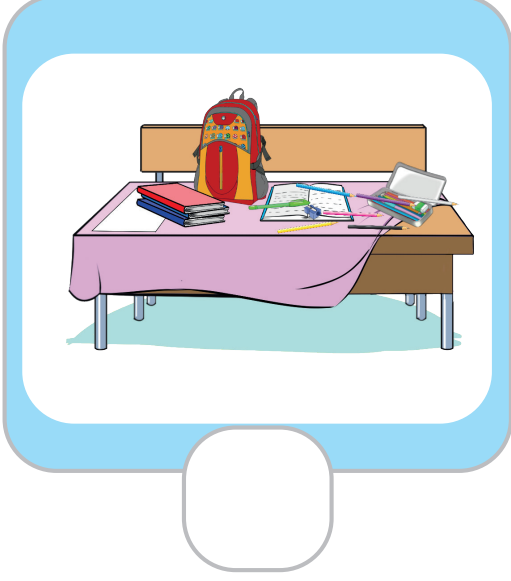

Çantan aşağıdakilerden hangisi gibi olmalı? İşaretle.



KONU

Yazı araç gereçlerini temiz ve düzenli kullanır.

KAZANIM

Yazı araç gereçlerini çalışma sonunda yerine koyar.

ETKİNLİK 1

Ders bittikten sonra kalemini, kalemtraşını ve silgini nereye koymalısın? İşaretle.

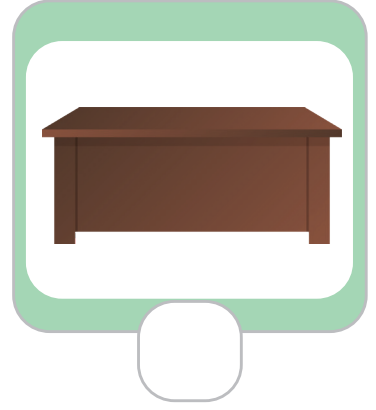

Ders bittikten sonra defterini ve kitabını nereye koymalısın? İşaretle.

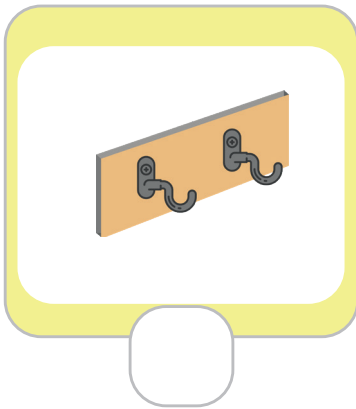

KONU

Yazı araç gereçlerini temiz ve düzenli kullanır.

KAZANIM

Defterini düzenli kullanır.

ETKİNLİK 1

Aşağıda bir defter sayfası var. Bu deftere yazı yazmaya nereden başlanır? İşaretle.



Aşağıdaki defter sayfasındaki kırmızı çizgi ne işe yarar? Bu defter sayfasına yazı yazmaya kırmızı çizginin neresinden başlanır? İşaretle.



ETKİNLİK 2

Aşağıdaki defterlerden hangisi düzenli kullanılmıştır? İşaretle.

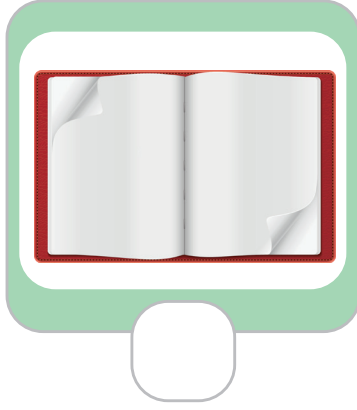
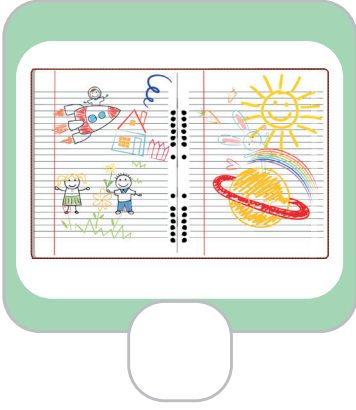

Defterin köşelerinin katlanmaması için aşağıdaki araçlardan hangisini kullanmalıyız? İşaretle.

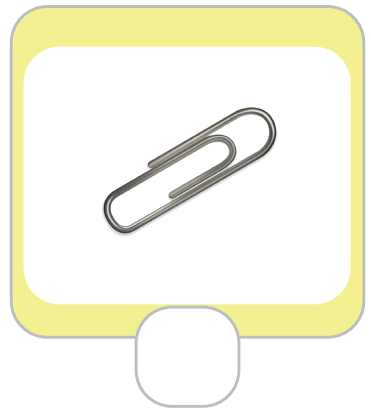
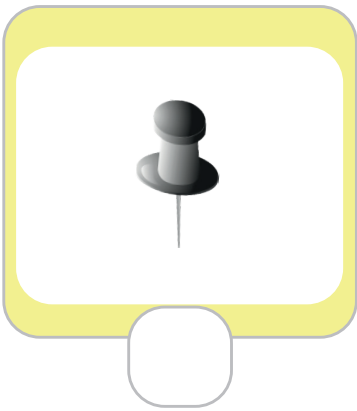
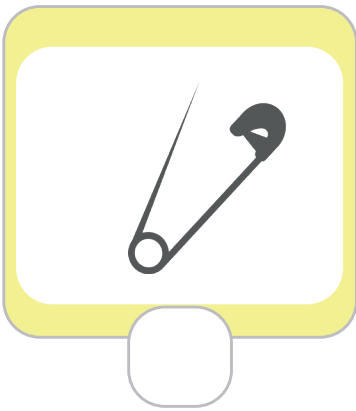

KONU

Noktaların üzerinden giderek çizgileri birleştirir.

KAZANIM

Dik çizgileri birleştirir.

ETKİNLİK 1

Aşağıdaki çiçeklerin üzerine yağan yağmurları çiz.

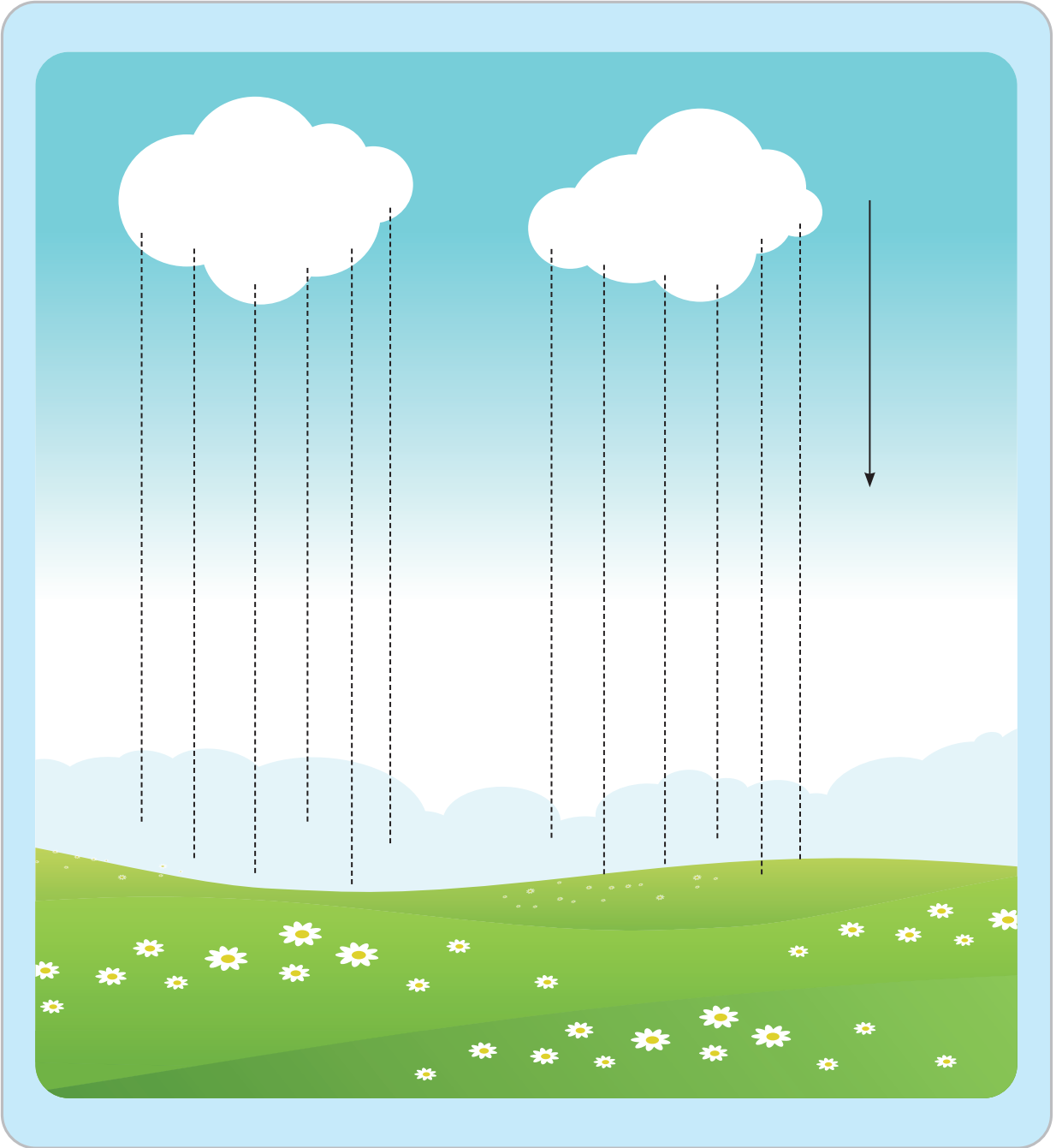

ETKİNLİK 2

Aşağıdaki ağacın yapraklarının yere doğru iniş yolunu çiz.

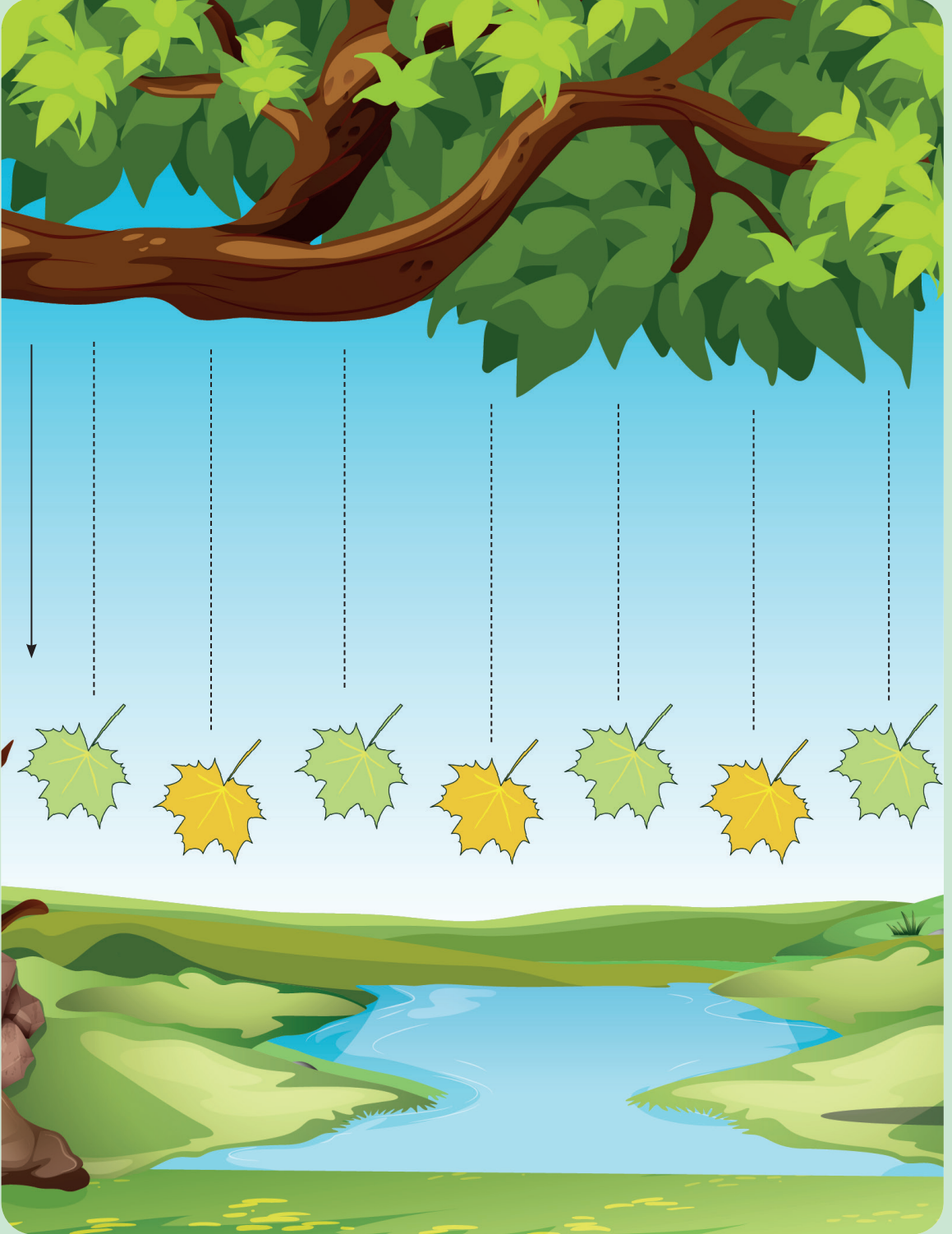

ETKİNLİK 3

Aşağıdaki uçurtmaların iplerini çocukların elinden başlayarak yukarı doğru çiz.

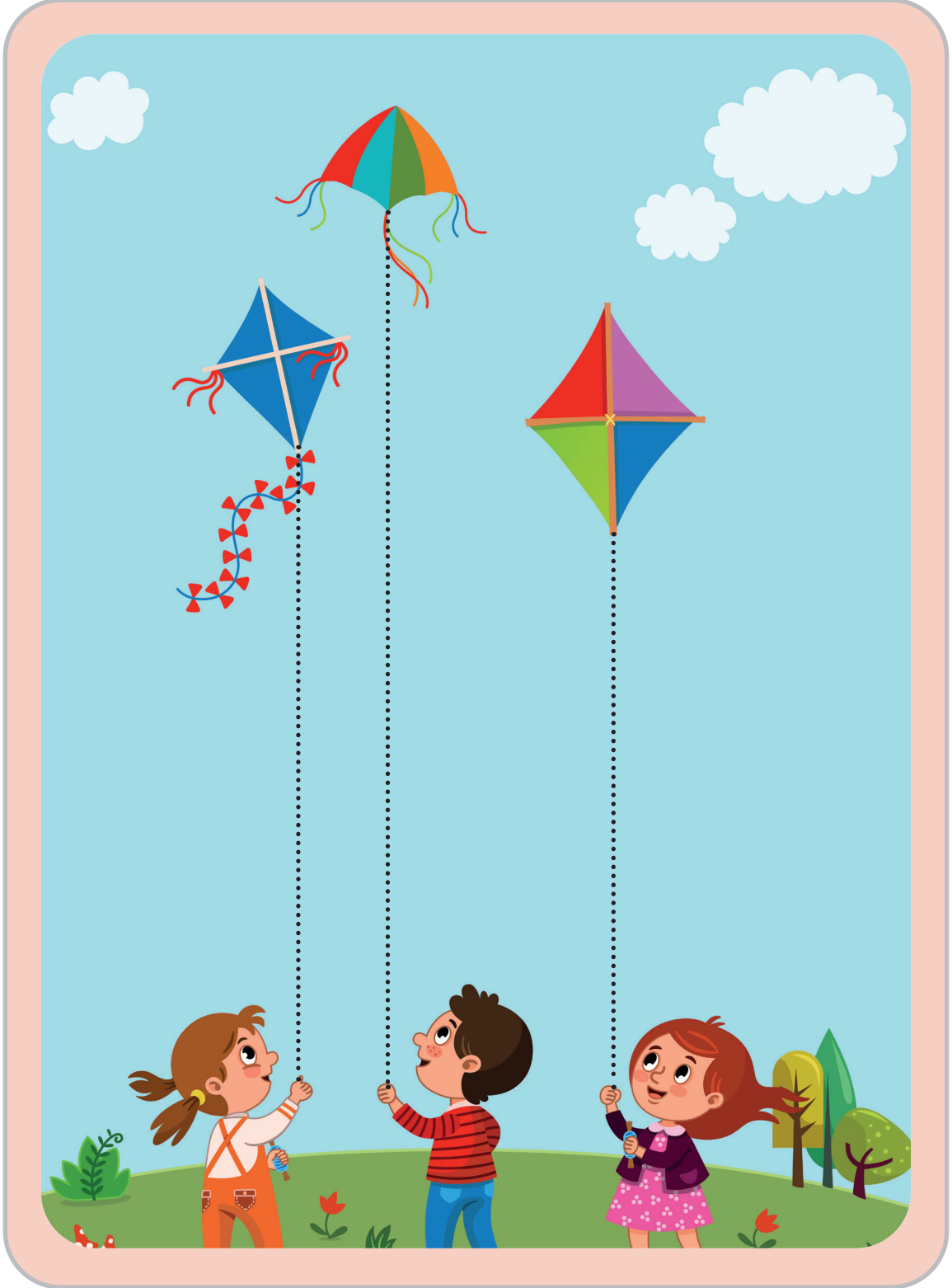

ETKİNLİK 4

Aşağıdaki balonların havaya uçağı yolu çiz.

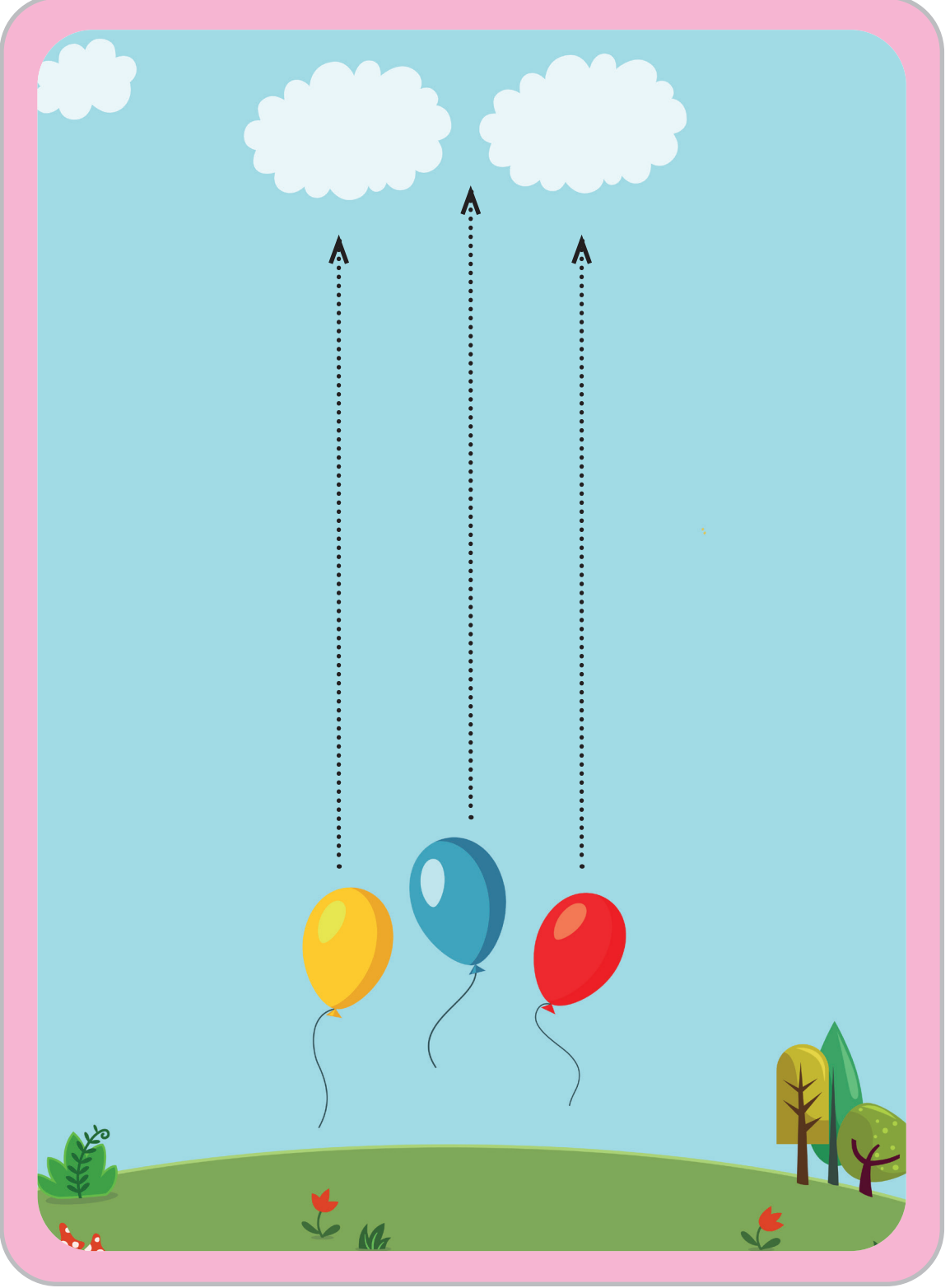

KONU

Noktaların üzerinden giderek çizgileri birleştirir.

KAZANIM

Yatay çizgileri birleştirir.

ETKİNLİK 1

Aşağıdaki çiçekleri saksılarına doğru çizerek ilerlet.

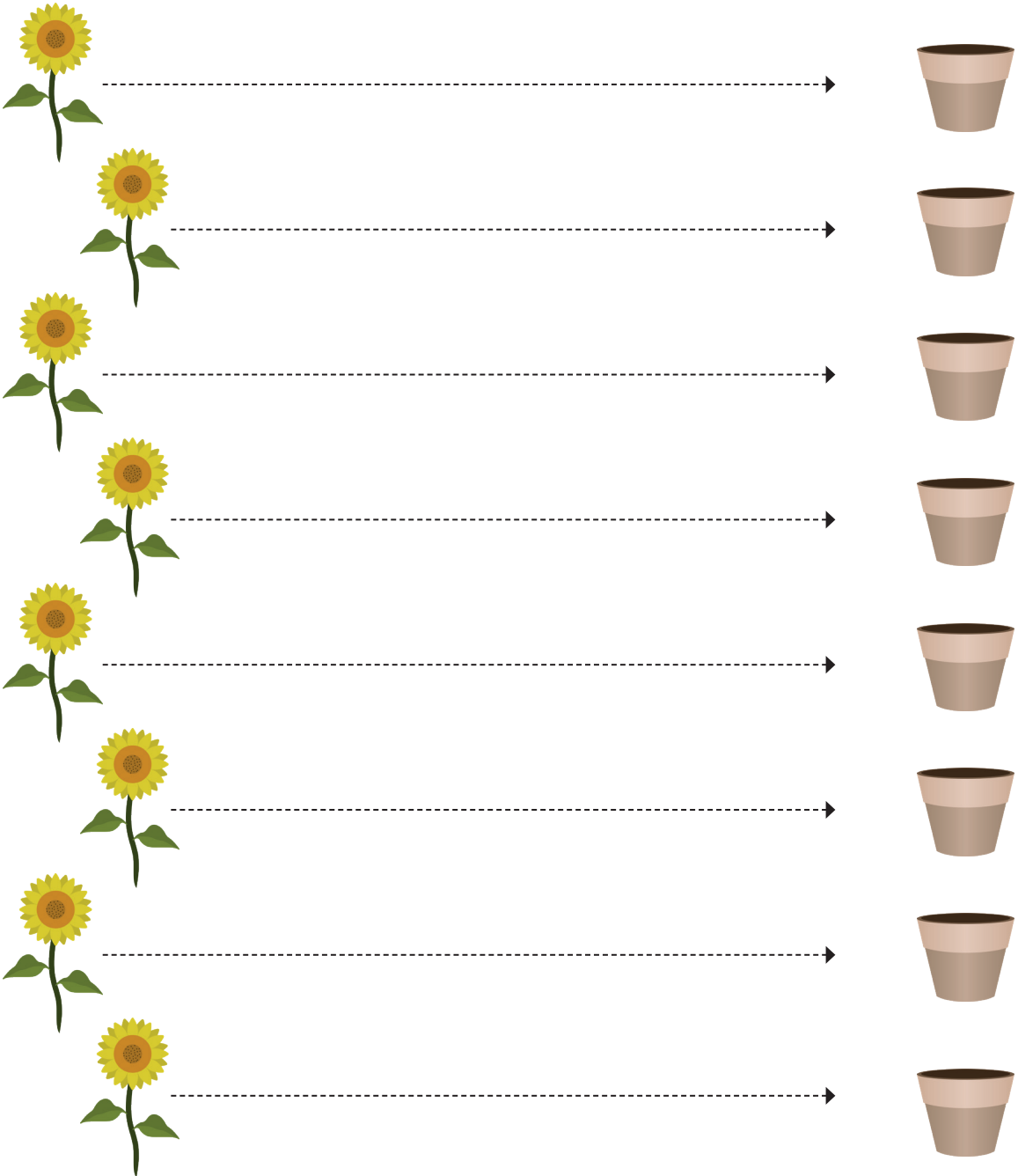

ETKİNLİK 2

Aşağıdaki taşıtların yollarını gösteren çizgileri çiz.

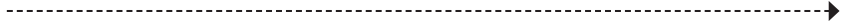
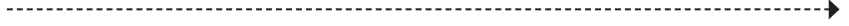
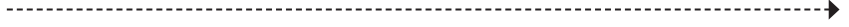
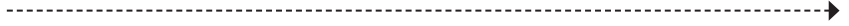
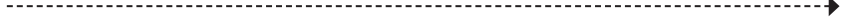

ETKİNLİK 3

Aşağıdaki hayvanları yiyeceklerine ulaştıracak yolu çiz.

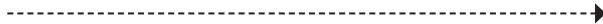
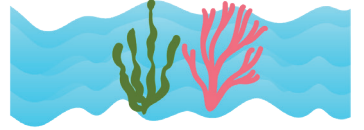
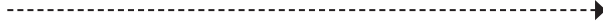
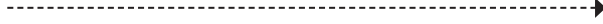
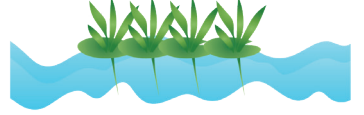
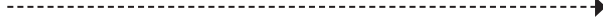
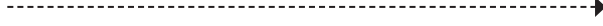

Aşağıdaki çocuğun kayak yapacağı yolu çiz.

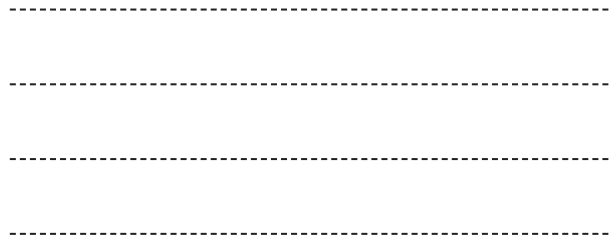

KONU

Noktaların üzerinden giderek çizgileri birleştirir.

KAZANIM

Yuvarlak çizgileri birleştirir.

ETKİNLİK 1

Aşağıdaki çocuğun toplarını ok yönünde çiz.

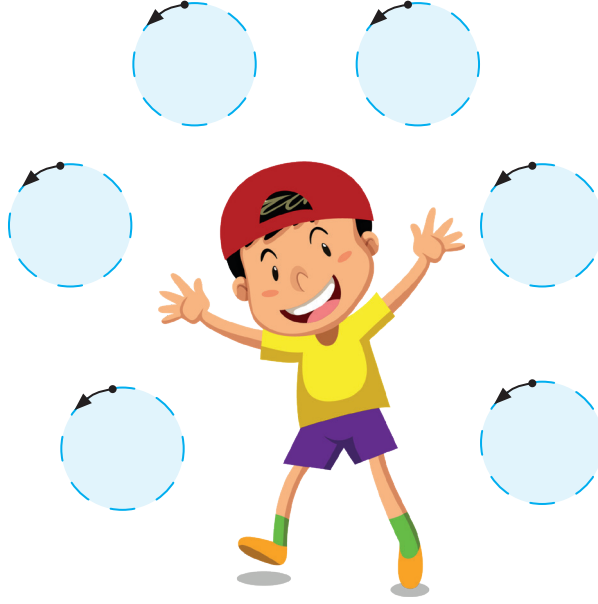

Aşağıdaki palyaçonun toplarını ok yönünde çiz.

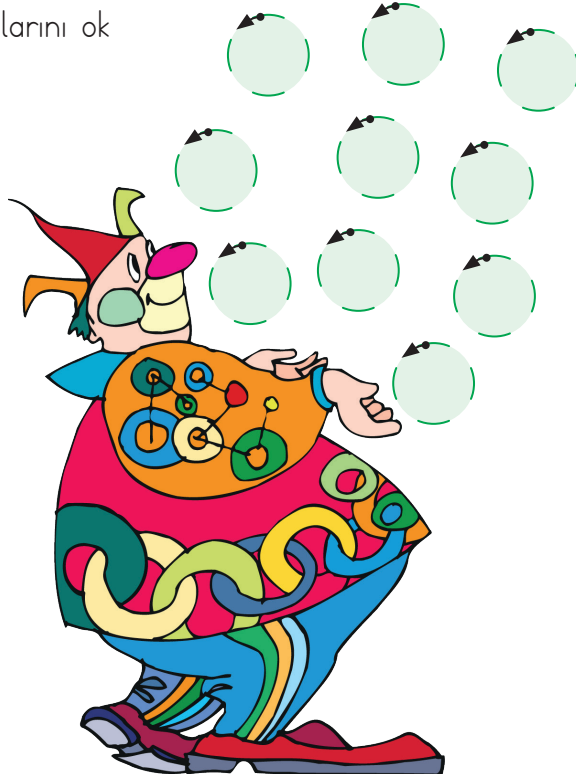

ETKİNLİK 2

Aşağıdaki üzüm tanelerini çiz.

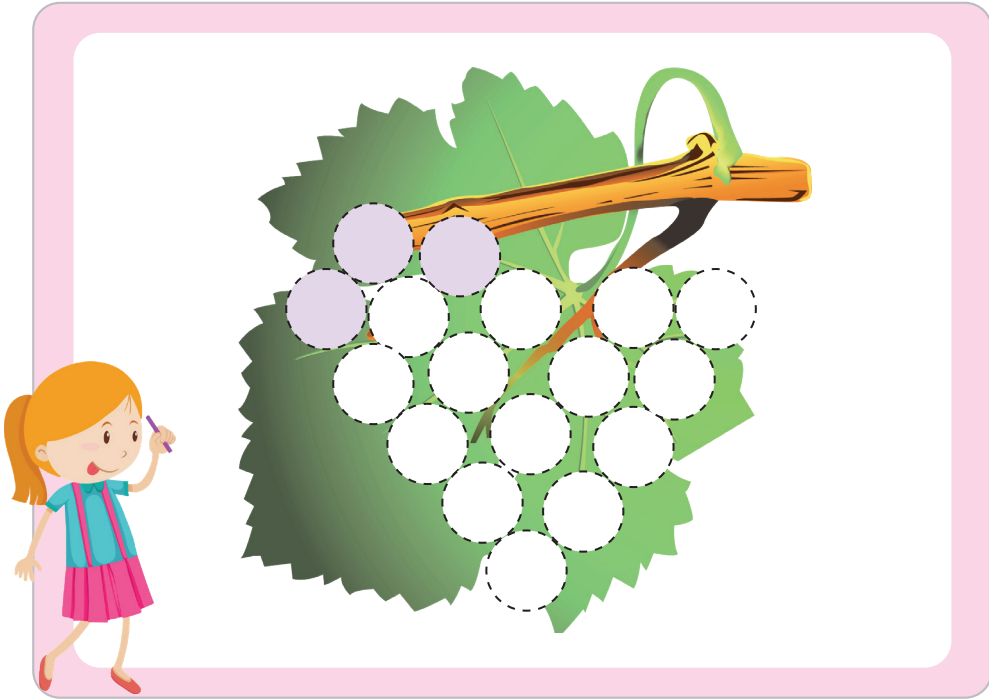

Aşağıdaki çiçekleri ve tırtılı çiz.

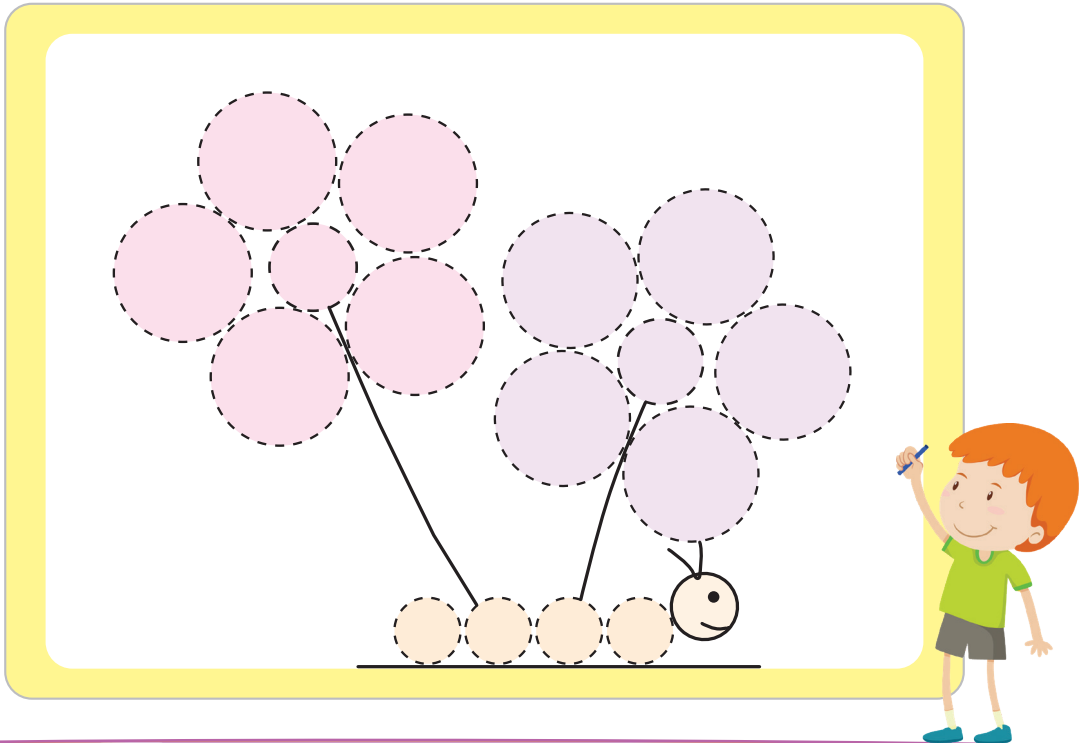

KONU

Noktaların üzerinden giderek çizgileri birleştirir.

KAZANIM

Eğik çizgileri birleştirir.

ETKİNLİK 1

Aşağıdaki tamircilerin tamir aletlerine giden yollarındaki çizgileri birleştir.

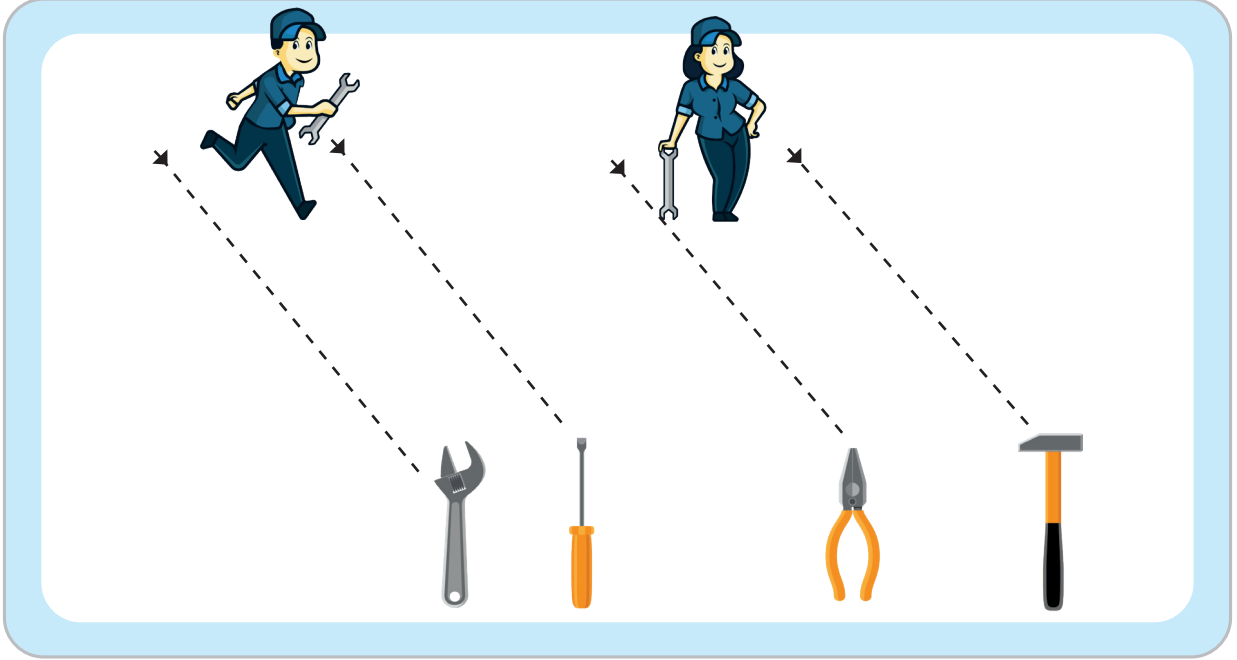

Aşağıdaki ağaçlardan dökülen yaprakların yollarını çiz.

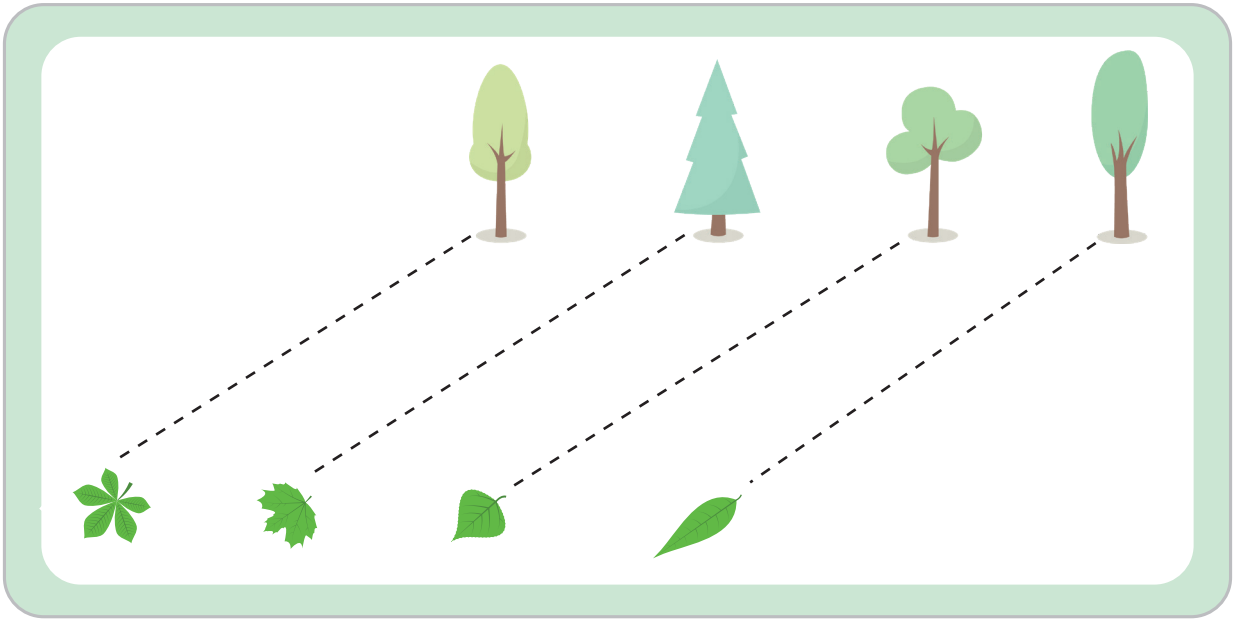

ETKİNLİK 2

Aşağıdaki duş başlığından akan suları gösteren çizgileri birleştir.



Aşağıdaki güneşin ışınlarını çiz.

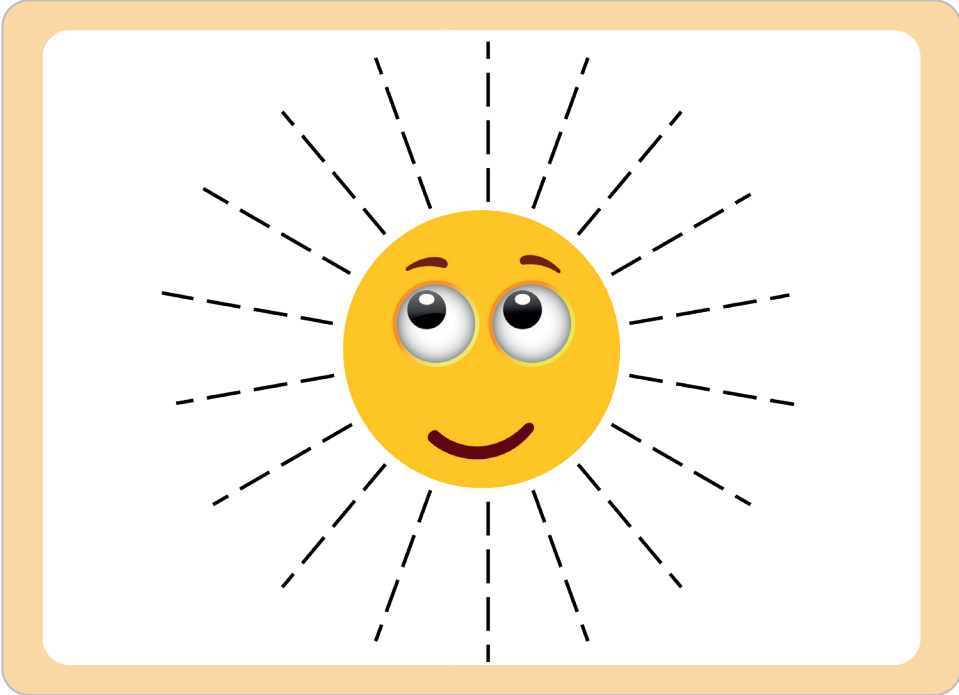

KONU

Noktaların üzerinden giderek çizgileri birleştirir.

KAZANIM

Dalgalı çizgileri birleştirir.

ETKİNLİK 1

Aşağıdaki köpeğin tasmaını gösteren çizgileri birleştir.

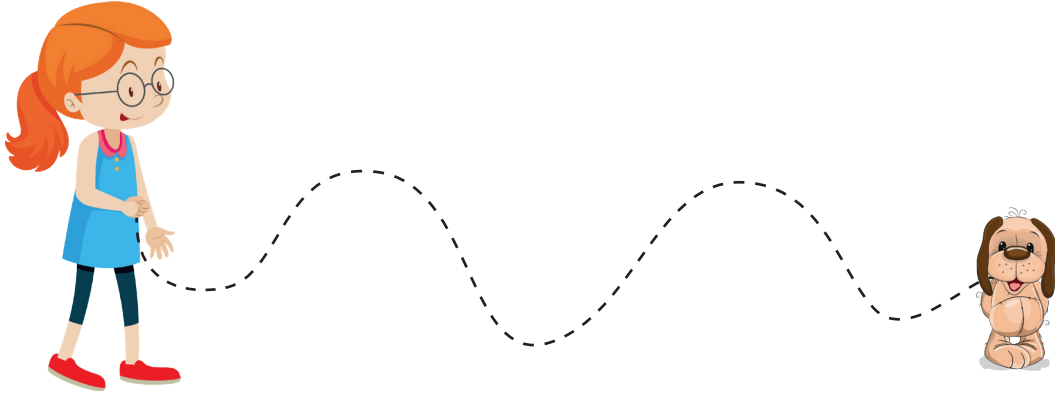

Aşağıdaki arının çiçeğe ulaşmak için kullanacağı yolu çiz.

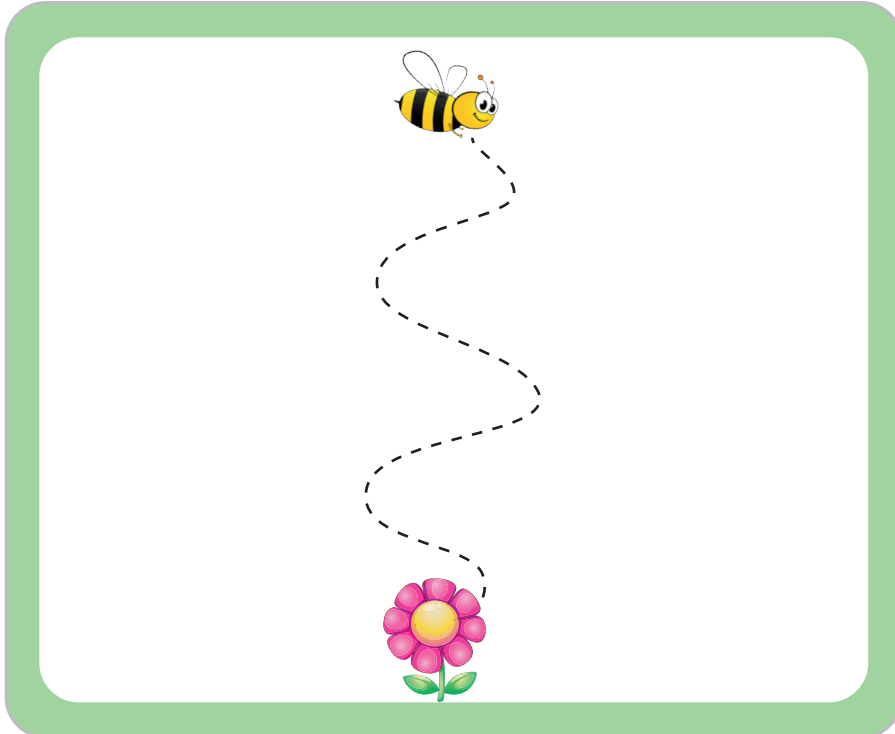

ETKİNLİK 2

Aşağıdaki kuşun ağaca doğru uçaacağı yolu çiz.

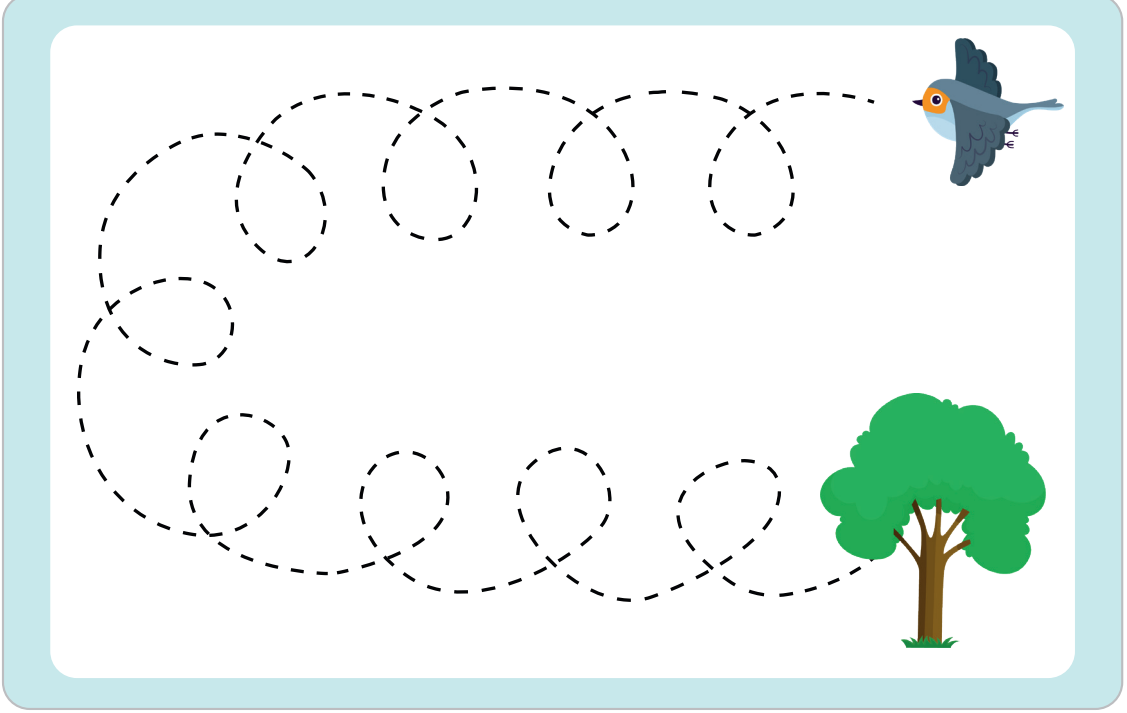

Aşağıdaki denizin dalgalarını gösteren çizgilerin üzerinden çiz.

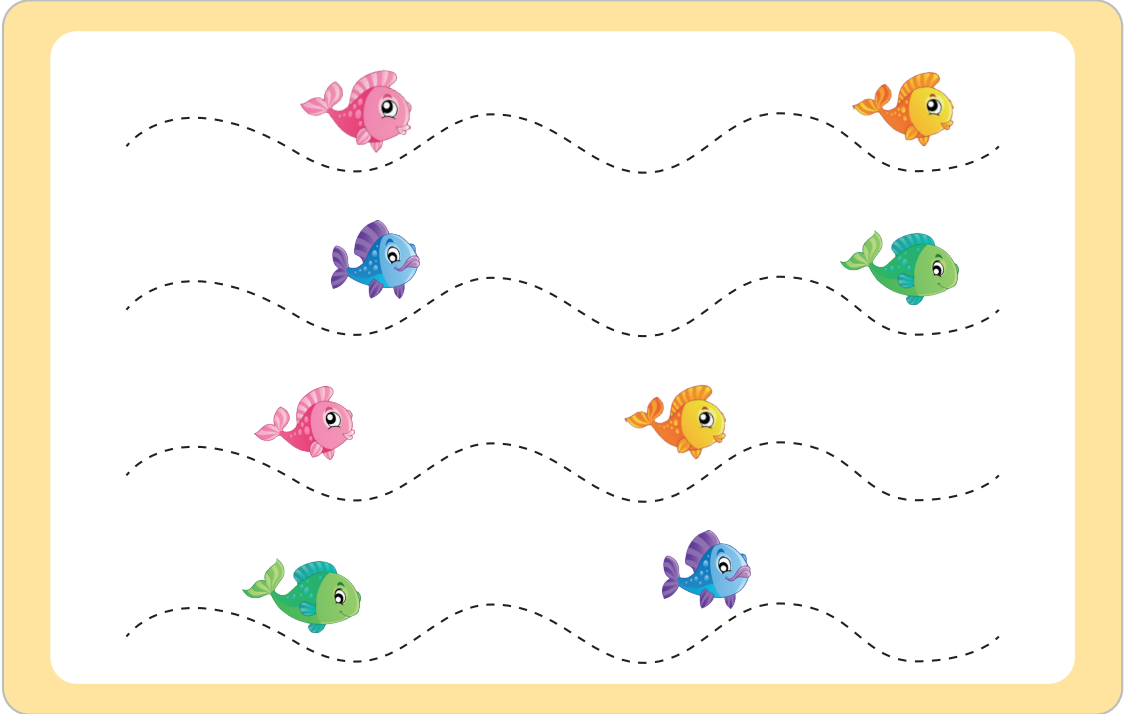

KONU

Noktaların üzerinden giderek çizgileri birleştirir.

KAZANIM

Kırık çizgileri birleştirir.

ETKİNLİK 1

Aşağıdaki hayvanların çiçeklere doğru ilerlediği yolu çiz.

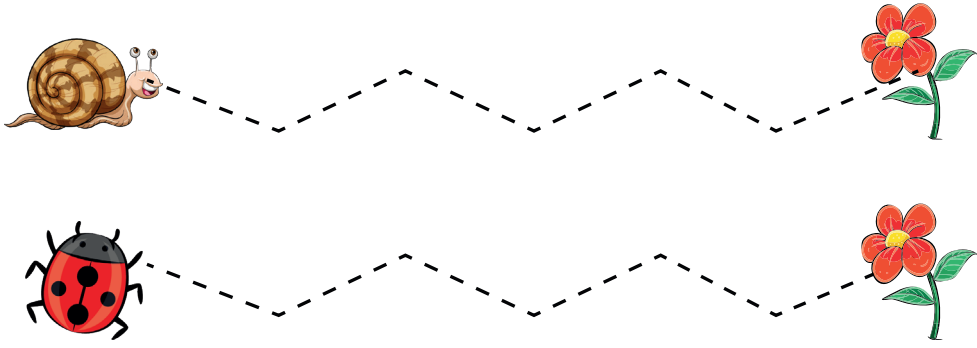

Aşağıdaki davulun desenlerini gösteren çizgileri çiz.

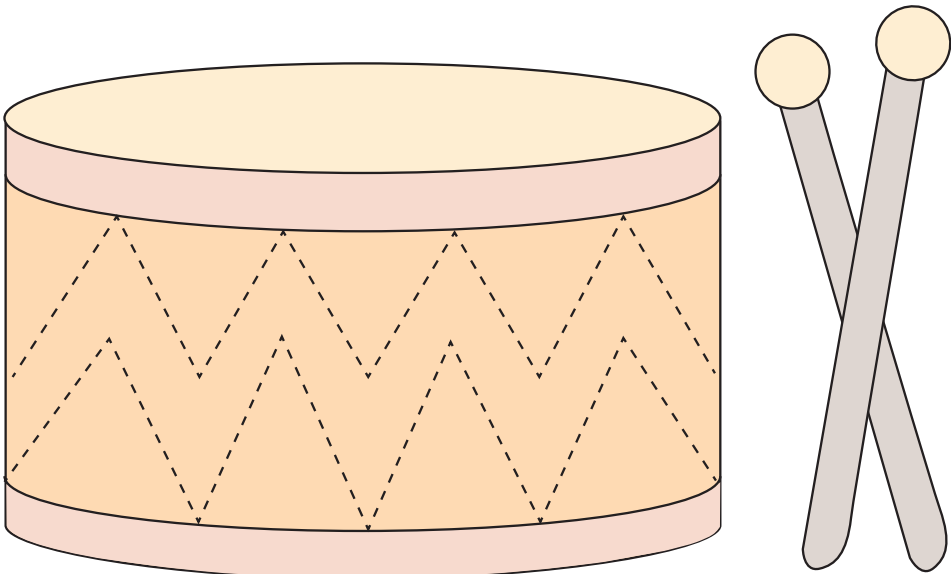

ETKİNLİK 2

Aşağıdaki halının desenlerini çiz.

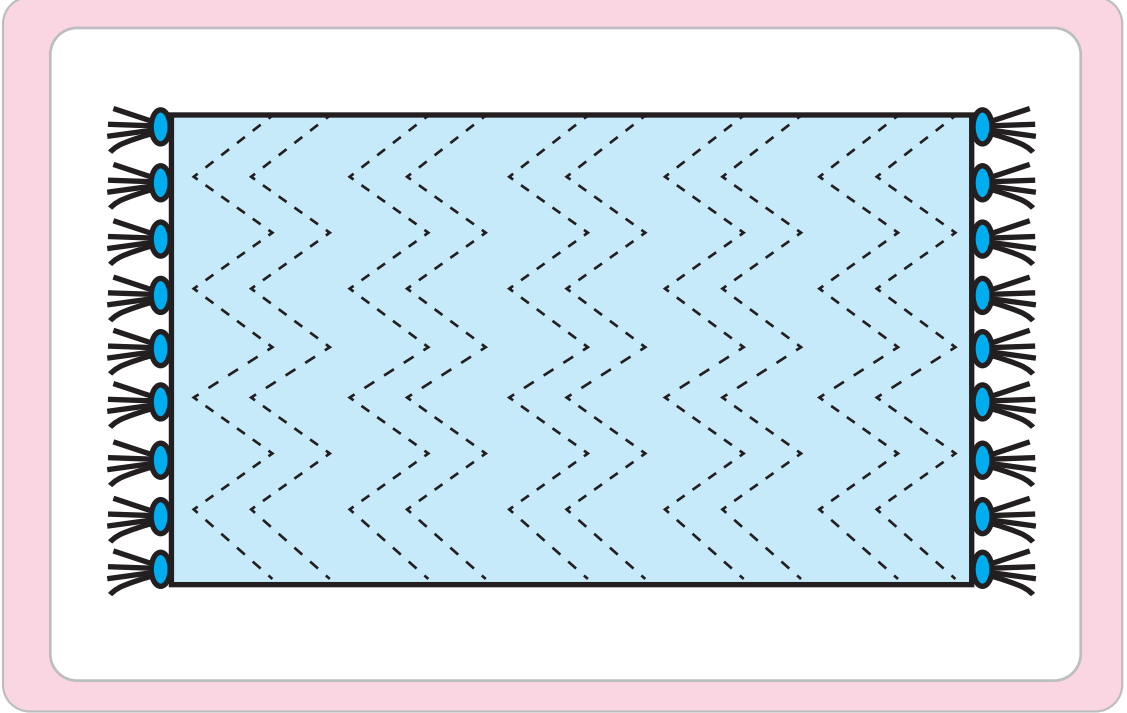

Aşağıdaki televizyon ekranında olan çizgileri birleştir.

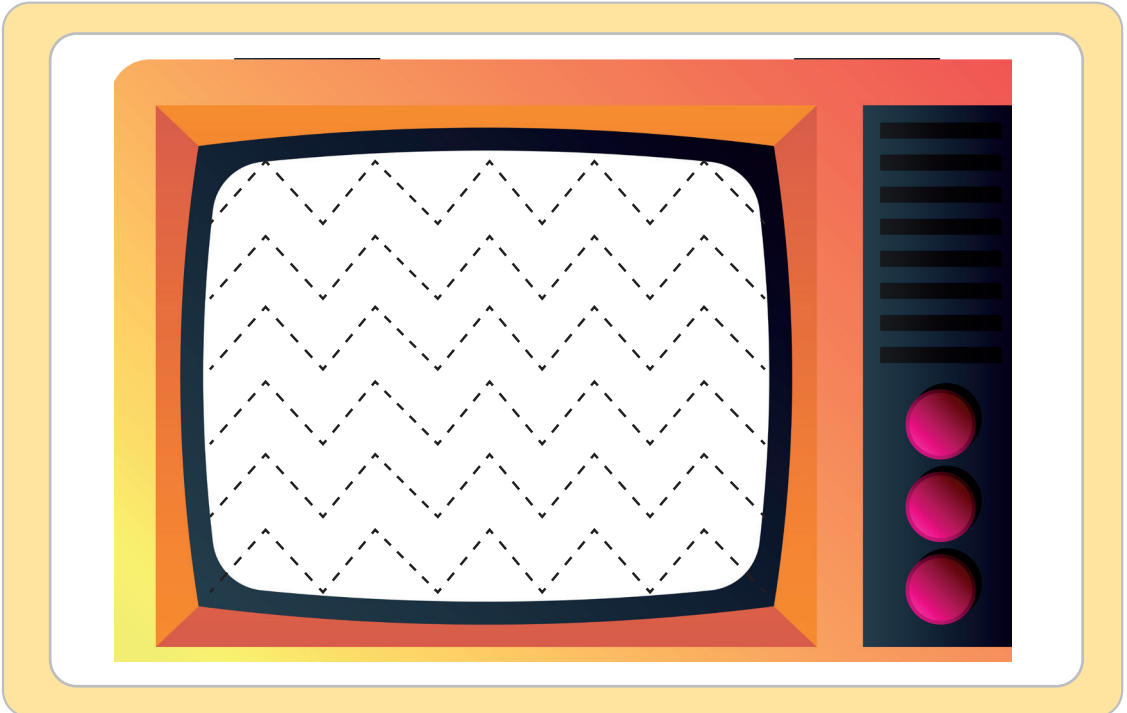

KONU

Noktaların üzerinden giderek çizgileri birleştirir.

KAZANIM

Noktaların üzerinden giderek şekil ve nesne resimleri çizer.

ETKİNLİK 1

Aşağıdaki noktaları birleştir. Resmi boya.

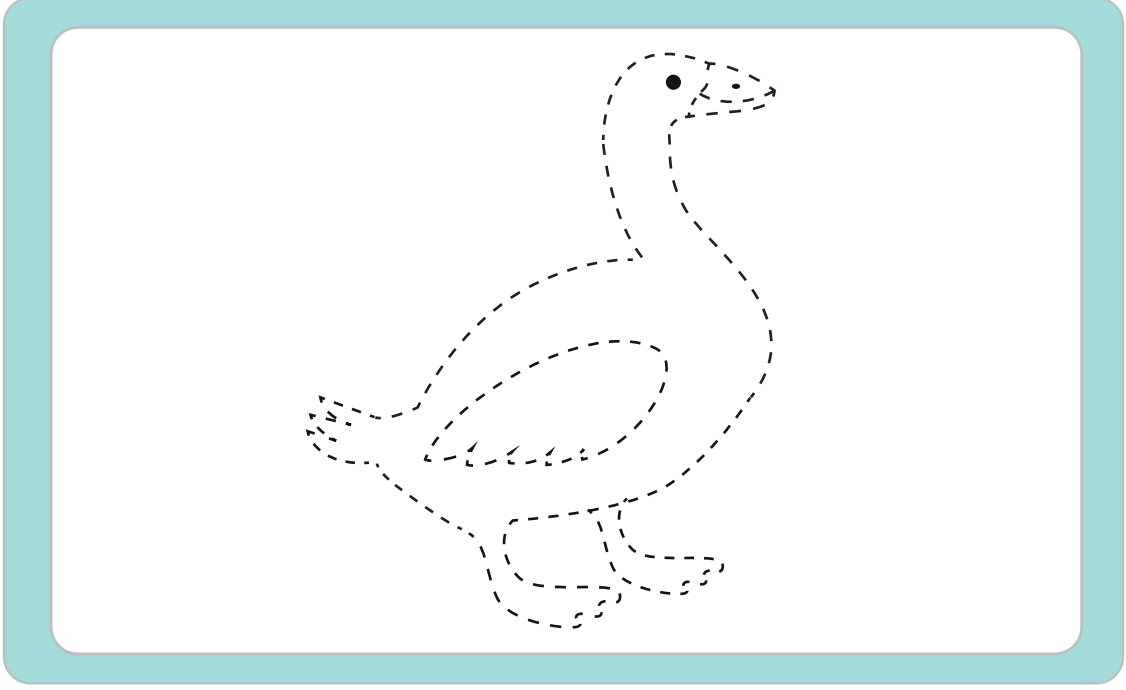

Aşağıdaki noktaları birleştir. Resmi boya.

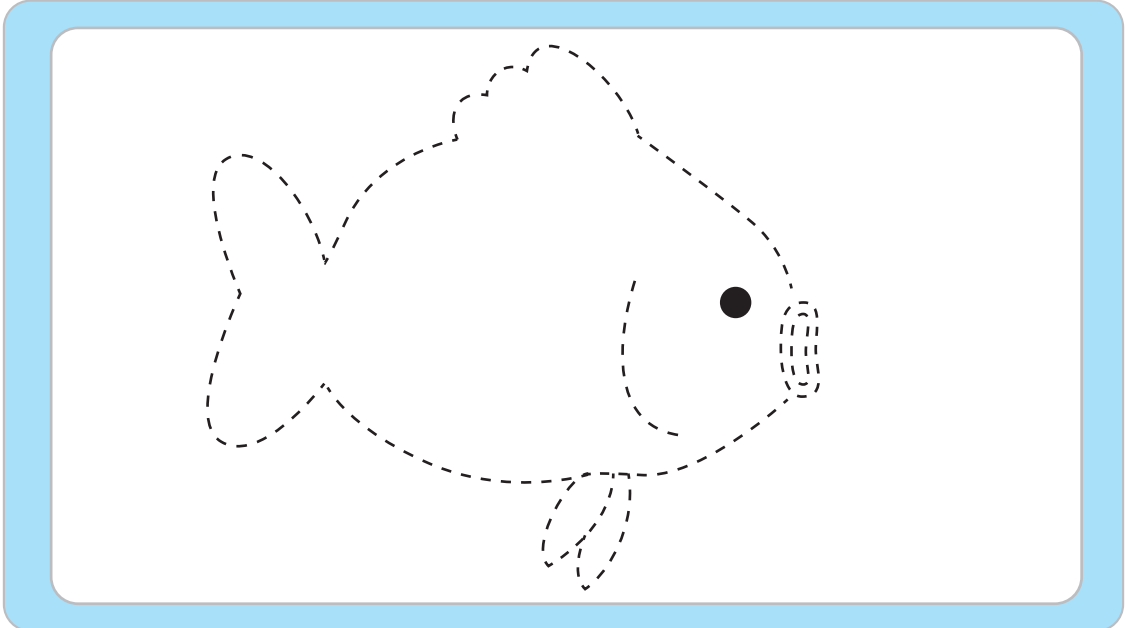

KONU

Tek satır aralığına harfleri oluşturan çizgileri çizer.

KAZANIM

Yatay çizgileri çizer.

ETKİNLİK 1

Ok yönünde noktaların üzerinden çiz.

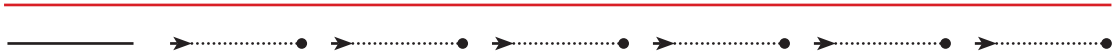

ETKİNLİK 2

Satır başındaki çizginin aynısını ok yönünde çiz.

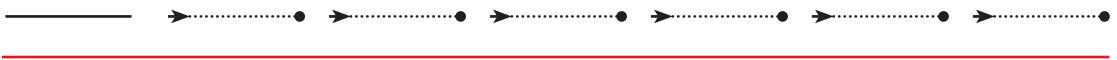
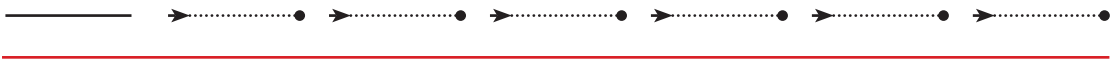
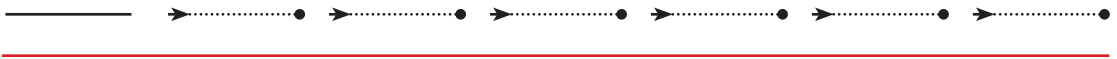
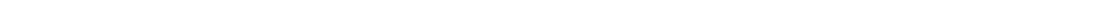
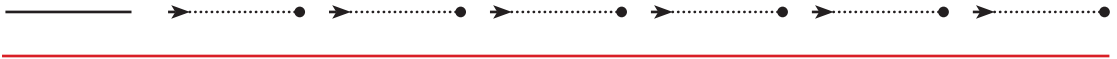
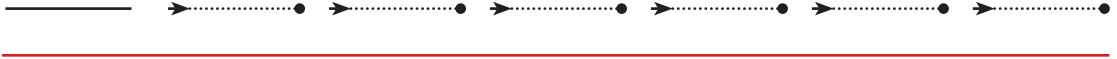
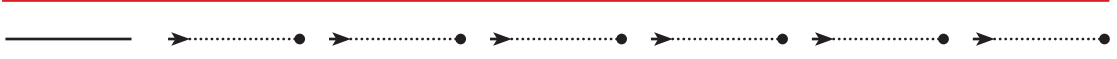

ETKİNLİK 3

Örneğe bakarak çiz.

The drawing area consists of ten identical sets of horizontal lines. Each set is contained within a rounded rectangular frame. The frame has a light blue border. Inside the frame, there are three horizontal red lines. The top and bottom lines are solid red. The middle line is also solid red, but it has a short black horizontal segment on its left side, extending from the left edge of the frame to the start of the red line. This black segment serves as a guide for drawing a vertical line that starts from the middle red line and goes down to the bottom red line.

KONU

Tek satır aralığına harfleri oluşturan çizgileri çizer.

KAZANIM

Dik çizgileri çizer.

ETKİNLİK 1

Ok yönünde noktaların üzerinden çiz.

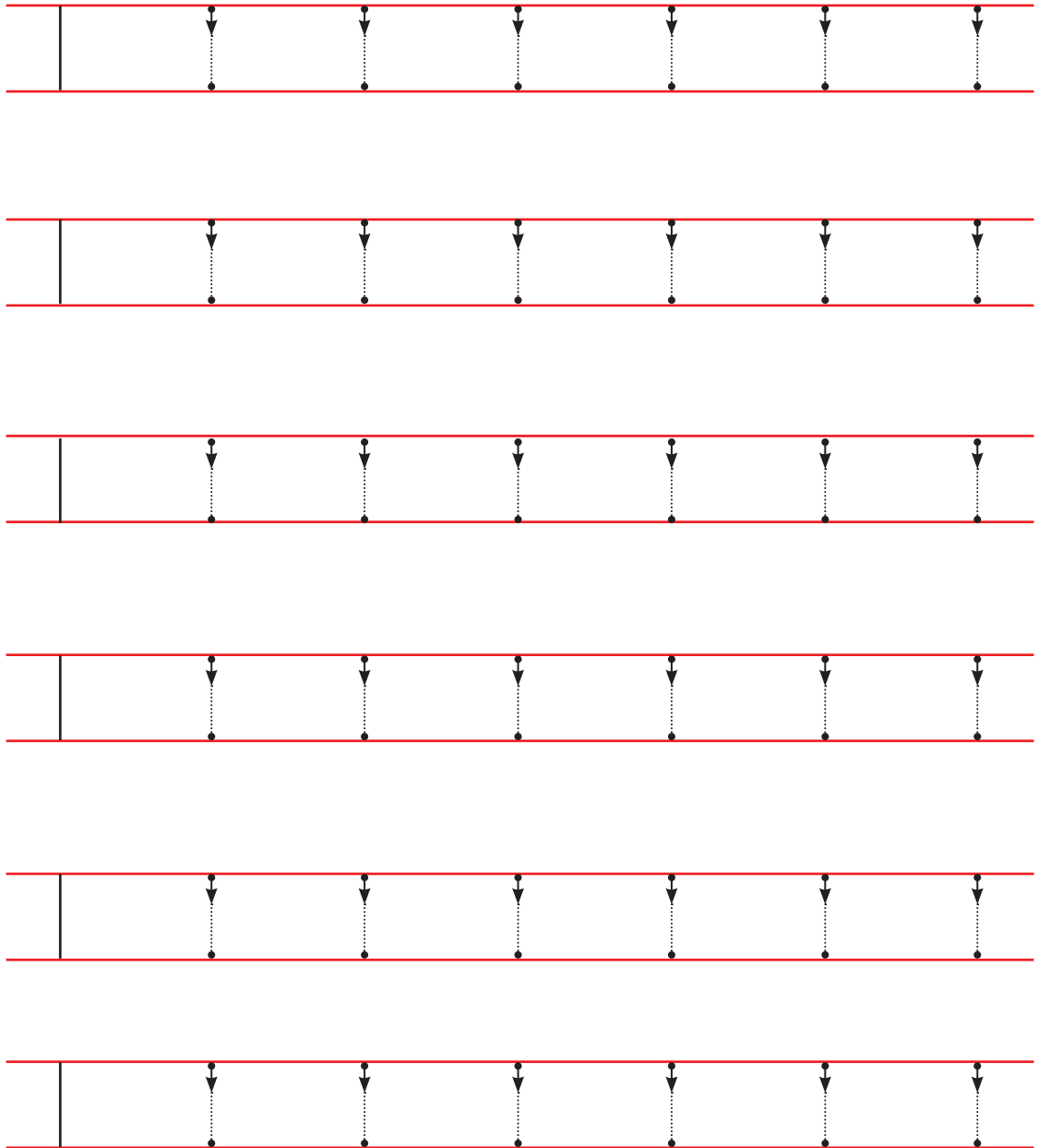

ETKİNLİK 2

Satır başındaki çizginin aynısını ok yönünde çiz.



ETKİNLİK 3

Örneğe bakarak çiz.

The image shows a large green-bordered box containing six sets of red horizontal lines. Each set consists of two horizontal lines with a vertical line on the left side, creating a columnar structure. This is a template for a drawing activity.

KONU

Tek satır aralığına harfleri oluşturan çizgileri çizer.

KAZANIM

Yuvarlak çizgileri çizer.

ETKİNLİK 1

Ok yönünde noktaların üzerinden çiz.

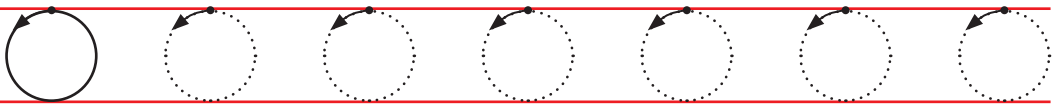
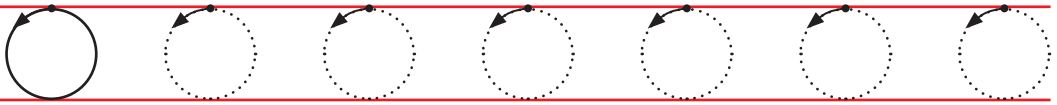
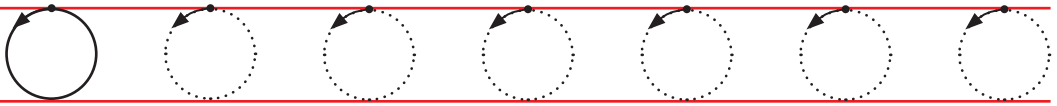
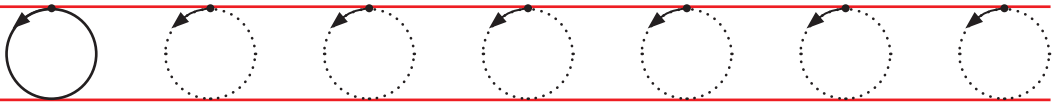
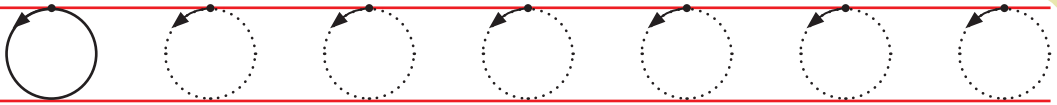

ETKİNLİK 2

Satır başındaki çizginin aynısını ok yönünde çiz.

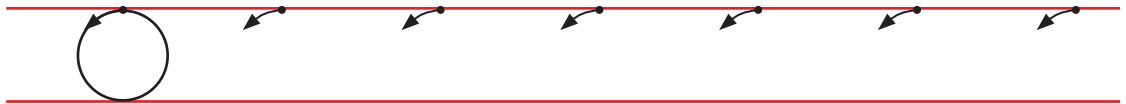
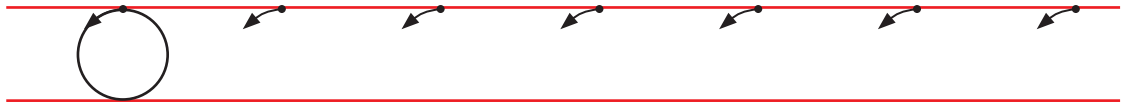
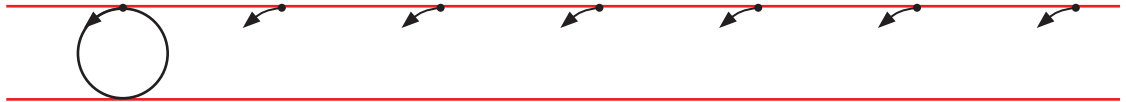
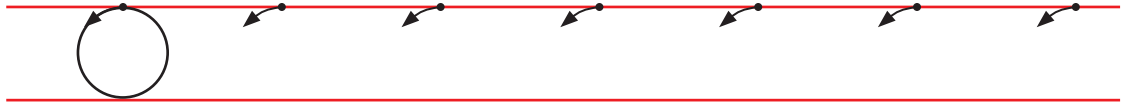
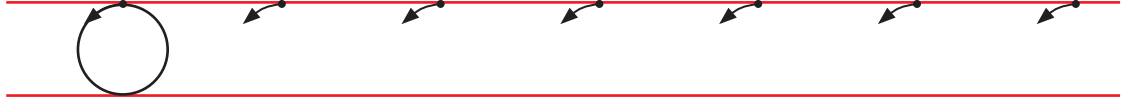
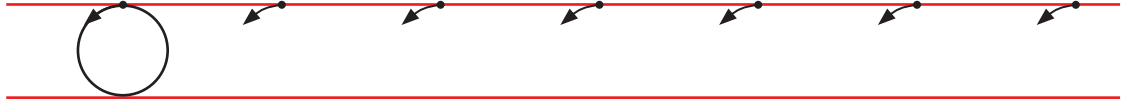

ETKİNLİK 3

Örneğe bakarak çiz.

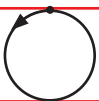
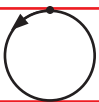
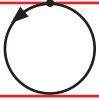
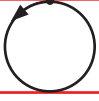
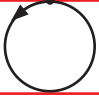

KONU

Tek satır aralığına harfleri oluşturan çizgileri çizer.

KAZANIM

Sağa eğik çizgileri çizer.

ETKİNLİK 1

Ok yönünde noktaların üzerinden çiz.

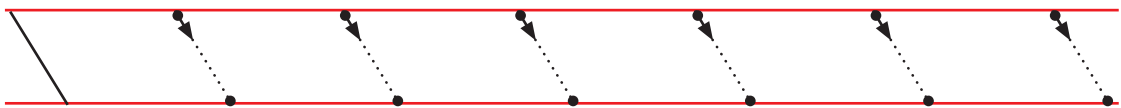
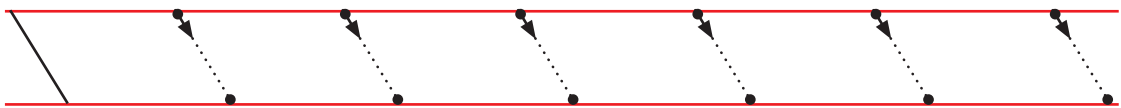
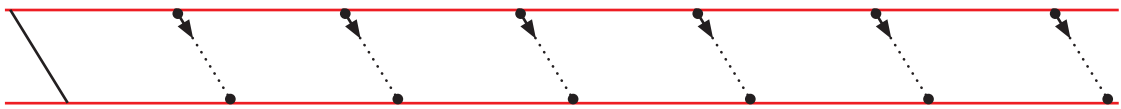
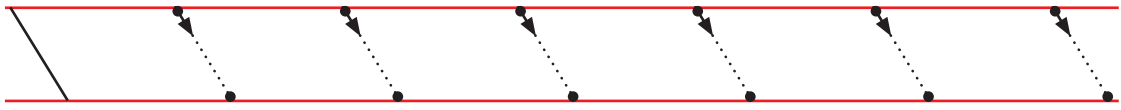
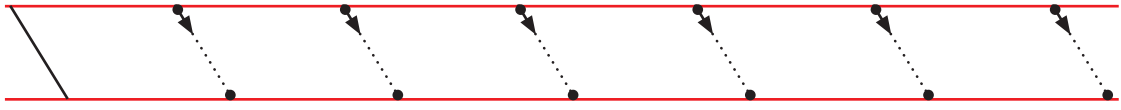
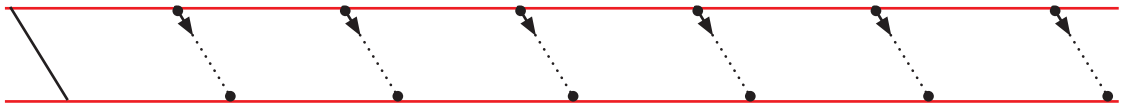

ETKİNLİK 2

Satır başındaki çizginin aynısını ok yönünde çiz.

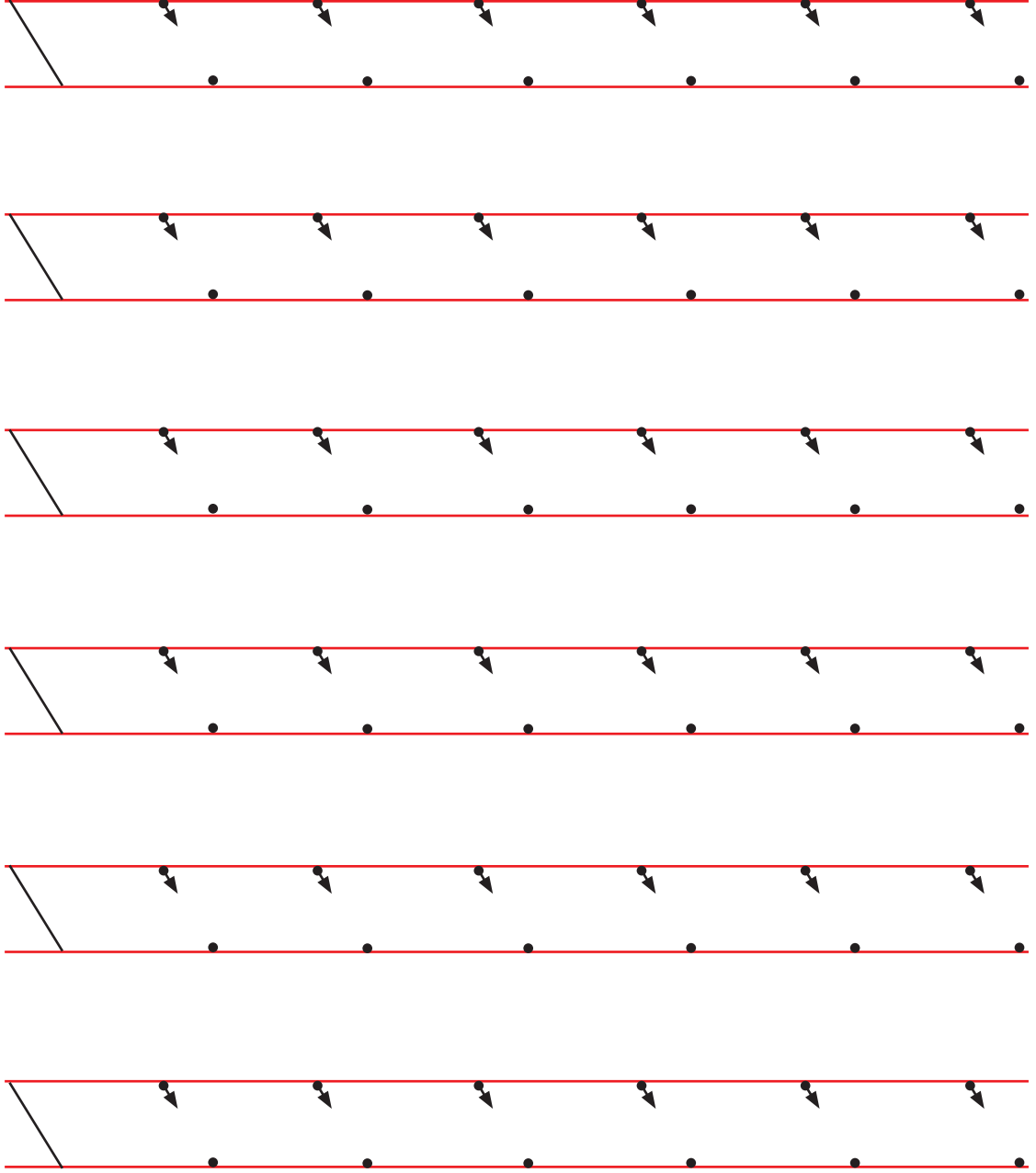

ETKİNLİK 3

Örneğe bakarak çiz.

The image shows a large green-bordered box containing six sets of red horizontal lines. Each set consists of two parallel red lines. On the left side of each set, there is a black diagonal line that starts at the top red line and slants downwards to the bottom red line. This is a visual example for a drawing activity.

KONU

Tek satır aralığına harfleri oluşturan çizgileri çizer.

KAZANIM

Sola eğik çizgileri çizer.

ETKİNLİK 1

Ok yönünde noktaların üzerinden çiz.

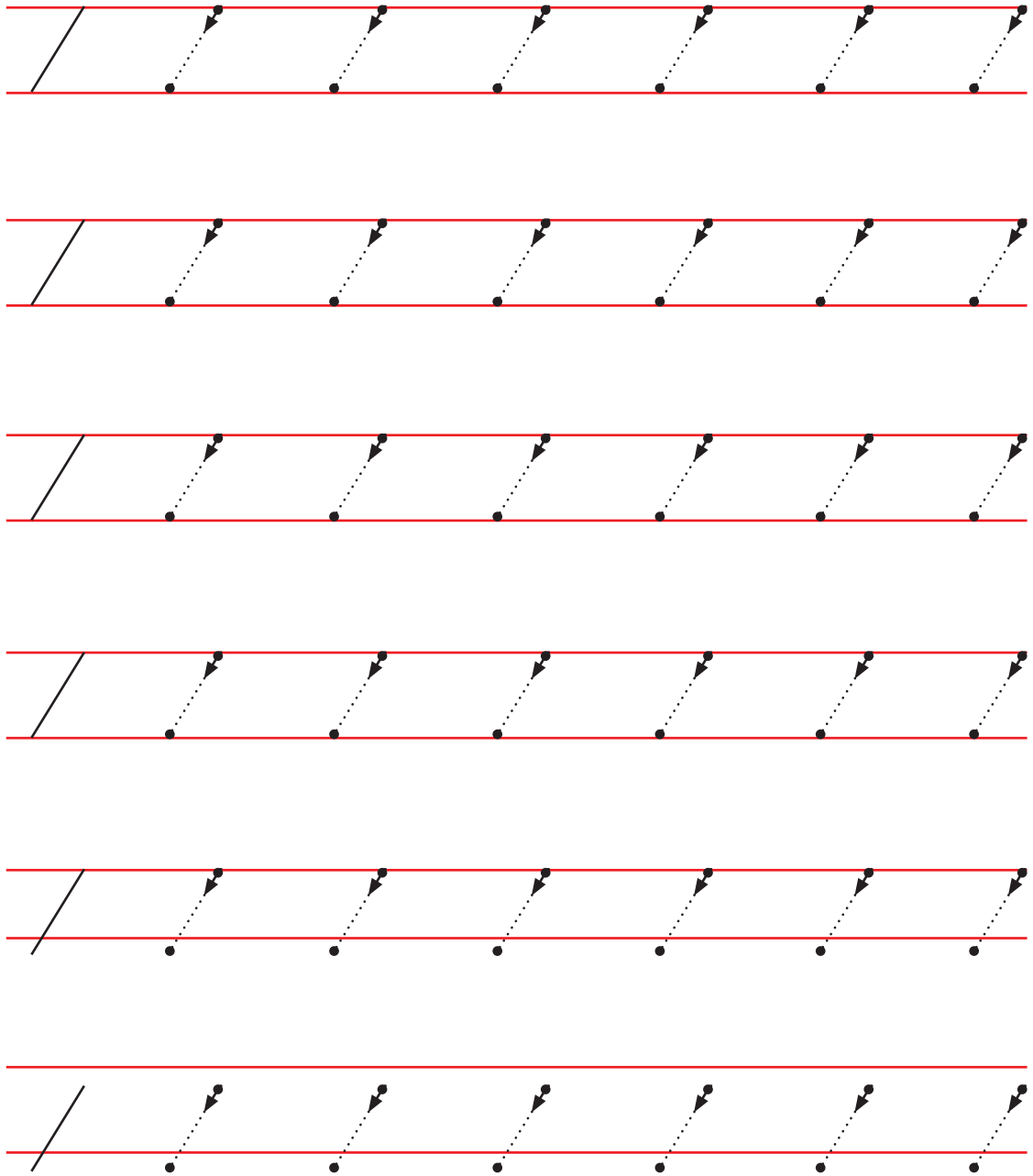

ETKİNLİK 2

Satır başındaki çizginin aynısını ok yönünde çiz.

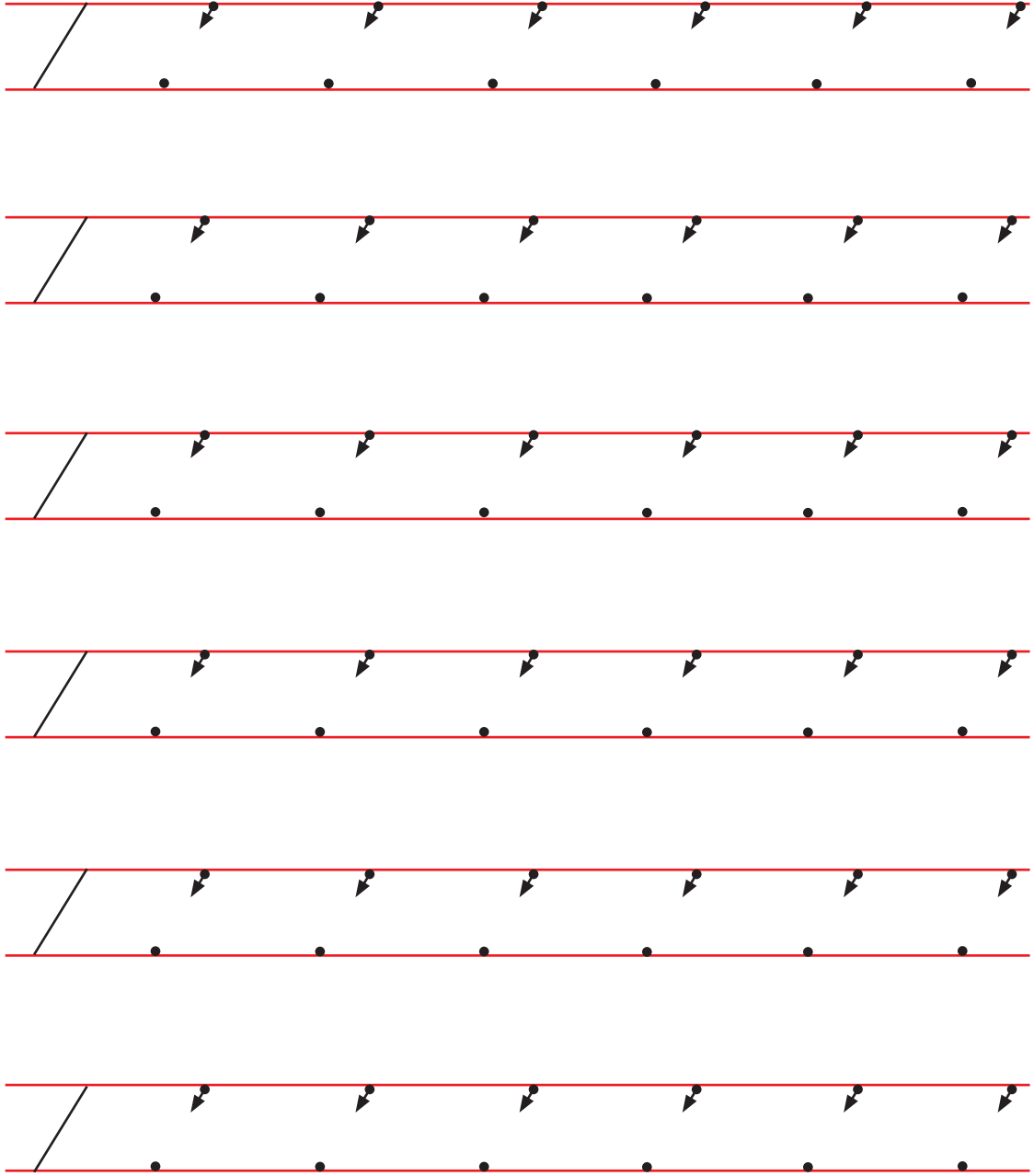

ETKİNLİK 3

Örneğe bakarak çiz.

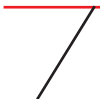

KONU

Tek satır aralığına harfleri oluşturan çizgileri çizer.

KAZANIM

Kıvrımlı çizgileri çizer.

ETKİNLİK 1

Ok yönünde noktaların üzerinden çiz.

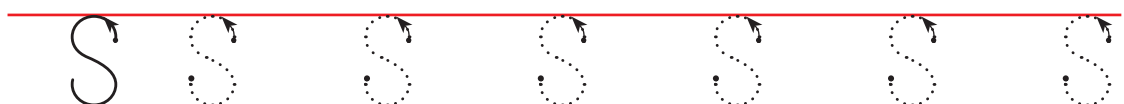

ETKİNLİK 2

Satır başındaki çizginin aynısını ok yönünde çiz.

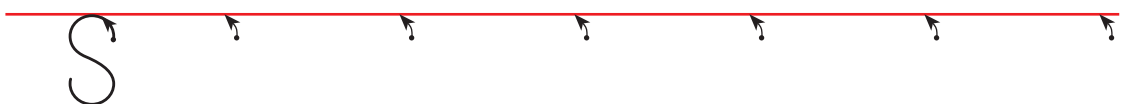

ETKİNLİK 3

Örneğe bakarak çiz.

S

S

S

S

S

S

ÖZEL ÖĞR
UYARLANMI
(U

TÜR

İLK OKU
1. SES



Özel Eğitim ve Rehberlik
Hizmetleri Genel Müdürlüğü

ÖZEL ÖĞRENCİLER İÇİN
UYARLANMIŞ ETKİNLİKLER
(UYET)

TÜRKÇE

İLK OKUMA-YAZMA
1. SES GRUBU



Özel Eğitim ve Rehberlik
Hizmetleri Genel Müdürlüğü

3

YARDIMCI



Bu kitabı tamamladın. Şimdi
bu kitaba geçebilirsin.

